



.....

STT20000A

.....

ATAPI Minicartridge Drive

.....

.....

.....

Product Manual

.....



© 1998 Seagate Technology, Inc. All rights reserved

No part of this publication may be reproduced in any form without written permission from Seagate Technology, Inc.

Publication Number *10005136-001*, March 1998

Seagate, Seagate Technology, the Seagate logo and Sidewinder are trademarks or registered trademarks of Seagate Technology, Inc. Other product names are trademarks or registered trademarks of their owners.

Seagate reserves the right to change, without notice, product offerings or specifications. Seagate Technology provides this manual "as is," without warranty of any kind, either expressed or implied, including, but not limited to, the implied warranties of merchantability and fitness for a particular purpose. Seagate Technology assumes no responsibility for the accuracy, completeness, sufficiency, or usefulness of this manual, nor for any problem that might arise from the use of the information in this manual.

FCC Notice

This equipment generates and uses radio frequency energy and, if not installed and used properly—that is, in strict accordance with the manufacturer's instructions—may cause interference to radio communications or radio and television reception. It has been tested and found to comply with the limits for a Class B computing device in accordance with the specifications in Part 15 of FCC Rules, which are designed to provide reasonable protection against such interference in a residential installation. However, there is no guarantee that interference will not occur in a particular installation. If this equipment does cause interference to radio or television reception, which can be determined by turning the equipment on and off, you are encouraged to try to correct the interference by one or more of the following measures:

- Reorient the receiving antenna.
- Relocate the computer with respect to the receiver.
- Move the computer into a different outlet so that the computer and receiver are on different branch circuits.

If necessary, you should consult the dealer or an experienced radio/television technician for additional suggestions. You may find the following booklet prepared by the Federal Communications Commission helpful: *How to Identify and Resolve Radio-TV Interference Problems*

This booklet (Stock No. 004-000-00345-4) is available from the U.S. Government Printing Office, Washington, DC 20402.

Caution. Changes or modifications made to this equipment which have not been expressly approved by Seagate Technology may cause radio and television interference problems that could void the user's authority to operate the equipment.

Further, this equipment complies with the limits for a Class B digital apparatus in accordance with Canadian Radio Interference Regulations.

Cet appareil numérique de la classe B est conforme au Règlement sur brouillage radioélectrique, C. R. C., ch. 1374.

Additional warnings:

- To prevent fire or electrical shock hazard, do not expose the unit to rain or moisture.
- To avoid electrical shock, do not open the cabinet. Refer servicing to qualified personnel.

Important Information About This Manual

All information contained in or disclosed by this document is considered proprietary by Seagate Technology. By accepting this material, the recipient agrees that this material and the information contained therein are held in confidence and in trust and will not be used, reproduced in whole or in part, nor its contents revealed to others, except to meet the purpose for which it was delivered. It is understood that no right is conveyed to reproduce or translate any item herein disclosed without express written permission from Seagate Technology.

Seagate Technology provides this manual "as is," without warranty of any kind, either expressed or implied, including, but not limited to, the implied warranties of merchantability and fitness for a particular purpose. Seagate Technology reserves the right to change, without notification, the specifications contained in this manual.

Seagate Technology assumes no responsibility for the accuracy, completeness, sufficiency, or usefulness of this manual, nor for any problem that might arise from the use of the information in this manual.

Table of Contents

Introduction	1
Drive overview	1
Features	3
Typical system configurations	4
Minicartridge technology overview.....	4
Flash EEPROM	5
Software	5
References	5
About this manual	6
Specifications	7
Overview	7
Physical specifications	7
Power specifications	9
Performance specifications	10
Environmental requirements	11
Reliability	12
Mean-Time-Between Failures	12
Mean-Time-To-Repair	12
Recommended tapes	13
Regulatory compliance	13
Installation	15
Introduction.....	15
Before you begin.....	15
Handling guidelines.....	15
Setting jumpers.....	16
Installing the drive	17
Mounting dimensions	18
ATA-2 Interface pin assignments	20
Drive operation and maintenance	23
Introduction.....	23
Front panel LED.....	23
Using Travan cartridges	24
Loading and unloading cartridges	24

Setting the write-protect switch	25
Loading revised firmware via Seagate firmware cartridge	26
Drive maintenance	27
Caring for tape cartridges	27
Cleaning the drive read/write head	27
Troubleshooting	28

ATAPI interface 31

Introduction.....	31
ATA-2 Interface	31
ATA-2 Signals	31
DASP-.....	31
PDIAG-.....	31
ATA registers	32
Status Register.....	32
Error Register.....	33
Feature Register	33
Supported ATA Commands	34
Execute Drive Diags (90h).....	34
Idle Immediate (E1h).....	34
Standby Immediate (E0h).....	34
Check Power Mode (E5h).....	34
Sleep (E6h).....	34
Set Features (EFh).....	35
ATAPI Identify Device (A1h).....	36
ATAPI Packet Command (A0h).....	37
ATAPI Soft Reset (08h).....	37
ATAPI interface	38
Reserved Fields.....	39
Erase command.....	40
Inquiry command	41
Load/Unload command.....	42
Locate command	43
Log Select command	44
Log Sense command.....	45
Error Counter Page (Read).....	46
Tape Capacity Page Code	47
Mode Select command	49
Mode Sense command	50
Mode Parameter Header	50

Mode Block Descriptor.....	51
Mode Medium Partition Page.....	52
Mode Capabilities and Mechanical Status Page.....	52
Mode Tape Parameters Page.....	53
Read command	54
Read Position command	55
Request Sense command.....	57
Rewind command	59
Space command.....	60
Test Unit Ready command.....	61
Write command	62
Write Filemark command.....	63
Write Buffer (download microcode) command	64

Tape format **65**

Introduction.....	65
Tape partitioning	65
Track positions	65
Track numbering.....	66
Track format	66
Frames.....	66
Blocks	68
Tape reference servo pattern.....	68
Write equalization	69
Randomization.....	69

Theory of operations **71**

Overview	71
Block diagram.....	71
Drive mechanisms	72
Mechanics	72
Cartridge-load mechanism.....	72
Capstan/drive-motor assembly	72
Chassis	72
Control circuits.....	72
Head design	73
Flash EEPROM	73
Sensors and switches.....	73
Drive media (Travan minicartridges).....	74

Glossary	75
-----------------	-----------

Acronyms and measurements	78
----------------------------------	-----------

Acronyms and abbreviations	78
Units of measurement.....	80

Introduction

1

Drive overview

The Seagate STT20000A extends the Seagate family of one-inch high, DC2000 drives that feature high performance, high reliability, and quiet operation. The drive transfers data at up to 60 megabytes per minute (Mbytes/min) without compression. With optimal system resources and compressible data structures, nominal transfer rates of up to 120 Mbytes/min can be observed using software data compression (assumes 2:1 compression ratio).

System optimizations include but are not limited to allocating the maximum amount of the base 640 Kbytes of memory available

Data compression is available within the Seagate Backup software package for DOS and Windows and typically provides for up to a 2:1 compression ratio. The compression ratio is dependent on the specific system and the nature of the files being compressed.

This drive optimizes throughput through the Seagate feature FastSense™. This feature enables the drive to automatically sense the fastest supportable data transfer rate of the host system and choose a transfer speed of either 1,000, 733, or 489 kilobytes/second (Kbyte/sec). This process maximizes system throughput by eliminating tape repositioning, which is typically required when the tape drive operates faster than the host computer.

The product is available as an internal device in either a 3.5-inch or half-high 5.25-inch configuration. The drive form factors are tailored for easy installation in today's computers.

The drive supports the QIC-3220-MC format standard and will provide 10 gigabytes uncompressed storage capacity, 20 gigabytes compressed, with a Travan TR-5 cartridge.

The drive will also read tapes conforming to the QIC-3095 standard.

A precision burst intelligent positioning system is used to achieve high track densities.

The STT20000A conforms to the QIC-3220-MC development standard adopted by Quarter-Inch Cartridge Drive Standards Inc. (QIC). The drive records in a serpentine fashion utilizing a 1,7 RLL (Run Length Limited) data encoding method, and provides for 108 data tracks and one (1) directory track on Travan TR-5 media.

The drive offers electronically erasable, programmable, read-only memory (flash EEPROM), which enables qualified Seagate OEMs to download revised firmware to the drive.

With the availability of greater capacity disk drives and the growth of small networks, the need for cost-effective, high-capacity storage has grown. The STT20000A is ideal for high-end standalone computers, workstations, and small networks.

Built using long-wearing materials and custom Large Scale Integration (LSI) components, the ATAPI drive was engineered for heavy-duty computer applications. Providing carefully controlled tape handling and rapid, smooth operation, the design promotes long life for key components such as the motors, drive heads, and the media itself. One major benefit of this new, computer grade engineering is low power consumption.

Figure 1-1 illustrates the STT20000A ATAPI minicartridge internal drive. Figure 1-2 illustrates the internal drive equipped with mounting brackets.

Figure 1-1
STT20000A internal drive without mounting brackets

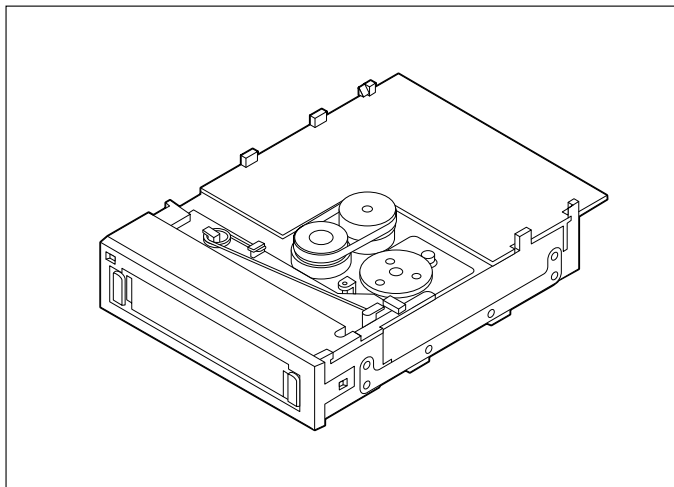
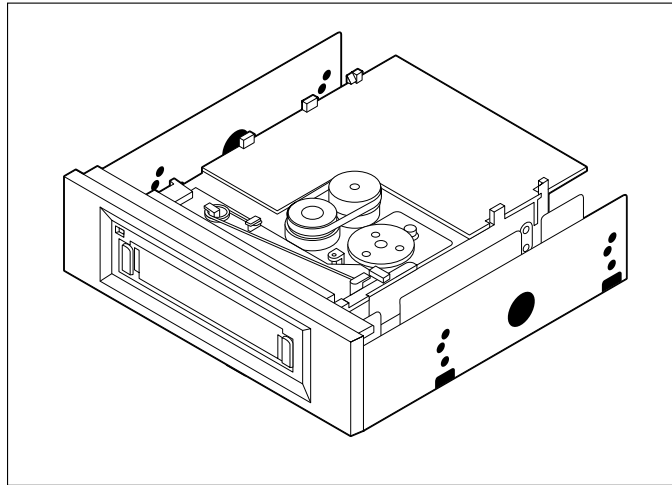

Figure 1-2
Internal STT20000A with mounting brackets



Features

The STT20000A embodies Seagate's commitment to engineer reliable and durable tape drive products. Key features of the drive are as follows:

- Internal form factor for installation in a 5.25-inch half-high or 3.5-inch by one-inch space
- Capability to write and read Travan TR-5 (QIC-3220-MC) media, as well as read TR-4 media conforming to the QIC-3095 standard
- QIC-3220-MC tape format compliance for compatibility and information interchange
- Typical uncompressed capacities of 10 gigabytes on 740 foot TR-5 media
- Typical compressed capacities of 20 gigabytes on 740 foot TR-5 media
- Transfer rate optimized with *FastSense*—automatic selection of fastest supportable data transfer rate (1,000, 733, or 489 Kbyte/sec)
- ATAPI interface that supports DMA and PIO modes 0, 1, or 2 with 512 Kbytes on-drive data buffer to facilitate the most efficient use of the host computer and tape drive.
- Uncorrectable error rate of less than 1 in 10^{15} bits
- Flash EEPROM to enable electrically upgradeable drive firmware
- Custom Seagate -designed LSI circuitry to reduce component count and boost drive reliability
- Low power consumption—less than 15.0 Watts (typical) for internal drives

Typical system configurations

The Enhanced IDE standard supports up to four ATAPI peripherals: two devices on the primary port and two devices on the secondary port. Of the two devices, one must be slave to the other, which is the master. Figure 1-3 shows sample configurations for two ATAPI systems.

Figure 1-3
Sample ATAPI configurations

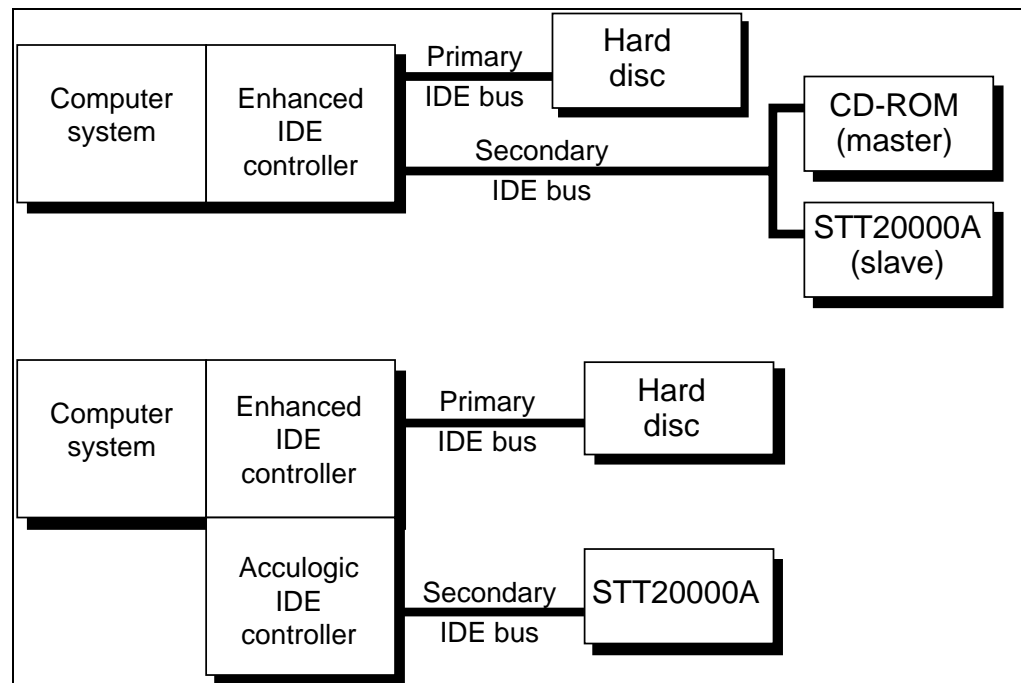

Minicartridge technology overview

Having evolved from the original mass-storage medium—reel-to-reel, 1/2-inch tape storage—the minicartridge technology of today offers fast, efficient, high-capacity storage in a compact, easy-removable hard-shell package. In little more than a decade, storage capacities have increased from some 60 megabytes (Mbytes) on 9 tracks (QIC-24, 1982) to the 20 Gbyte capacity achievable with the STT20000A minicartridge drive on a single Travan TR-5 cartridge.

The streaming-tape intelligence in the STT20000A provides a continuous tape motion with an uninterrupted, precisely coordinated flow of data to and from the minicartridge. This "streaming" motion combined with the "serpentine" recording method is one element that contributes to the increased storage capacities, efficiency, and speed of today's minicartridge technology.

Use of the "serpentine" recording method exploits the bi-directional capabilities of the cartridge. With this method, the tape is not rewound at the end of a track.

Instead, the write-read heads are logically or mechanically switched to a different position on the tape and another track is written or read in the reverse direction. That is, the drive first records track 1 in one direction and when the end of the tape is reached, the head is moved and the direction of tape motion is reversed to record track 2. This serpentine process continues until the entire tape is recorded. The individual tracks are sequential to minimize the amount of head motion as the heads change position for each track.

Flash EEPROM

The STT20000A incorporates leading-edge technology in the flash EEPROM, which is useful should the drive's firmware need to be upgraded at some point. With the permanently installed, electrically upgradeable, flash EEPROM memory, revised firmware for the drive can be loaded via any one of two methods:

- Seagate OEM firmware cartridge (See chapter 4)
- Host IDE bus

This feature enables qualified OEMs needing to revise the drive firmware to do so rapidly and at a reduced cost. Flash EEPROM should also prolong the life cycle of a drive because many new techniques—such as increasing the capacity of the drive through support for longer tapes—may require only a firmware upgrade.

Software

The STT20000A is a cost-effective means of backing up fixed disks. The drive is compatible with DOS™ version 5.0 or later, Microsoft Windows™ 3.1 or later, Microsoft Windows 95, or Windows NT and will operate with many of the popular backup software applications such as Seagate's Backup for DOS and Windows, Windows 95, NetWare, or Windows NT.

References

The following standards documents describe some of the technology incorporated in the drives referenced in this manual.

- **QIC-170**—Preformatted magnetic minicartridge
- **QIC-157**—ATAPI command set for streaming tape
- **QIC-3095-MC**—Serial recorded magnetic tape minicartridge (TR-4)
- **QIC-3220-MC**—Serial recorded magnetic tape minicartridge (TR-5)

For more information about a particular QIC standard, contact Quarter-Inch Cartridge Standards, Inc., c/o Freeman Associates, 311 East Carrillo Street, Santa Barbara, California 93101.

About this manual

The remaining chapters and the appendices in this manual are briefly described in the following table. A glossary of terms is also included.

<i>Chapter</i>	<i>Title</i>	<i>Description</i>
2	Specifications	Contains physical, performance, environmental, reliability, power, and minicartridge specification tables.
3	Installation	Provides cautions, unpacking tips, inspection information, and installation/connection steps including cabling requirements and connector pinouts.
4	Drive operation and maintenance	Explains the simple operation of the drive.
5	ATAPI Interface	Lists general information about the interface.
6	Tape format	Provides an overview of the QIC-3220 tape format.
7	Theory of operation	Details the functional operation of various assemblies of the ATAPI drive.
Appendix A	Glossary	Defines key terms.
Appendix B	Acronyms and measurements	Lists the acronyms and measurements used in the manual.

Specifications

2

Overview

The STT20000A provides exceptional reliability in storing large amounts of computer data. This chapter includes the following specifications and requirements:

- Physical specifications
- Power requirements
- Drive performance specifications
- Environmental requirements
- Recommended tapes
- Tape capacities and formats
- Regulatory compliance

Physical specifications

The physical specifications of the STT20000A are listed in the following table.

Specification	Drive for 3.5-Inch Mount	Drive for 5.25-Inch Mount
Height	1.0 in/ 25 mm	1.7 in/ 43 mm
Width	4.0 in/102 mm	5.87 in/149.1 mm
Length	6.36 in/161.5 mm	6.51 in/165.5 mm
Weight	1.0 lbs/0.5 kg	1.5 lbs/0.7 kg

Figures 2-1 and 2-2 show the general dimensions of the STT20000A in 3.5-inch configuration (without mounting brackets) and in the 5.25-inch configuration (with mounting brackets).

Figure 2-1
STT20000A (3.5-Inch mount) general dimensions

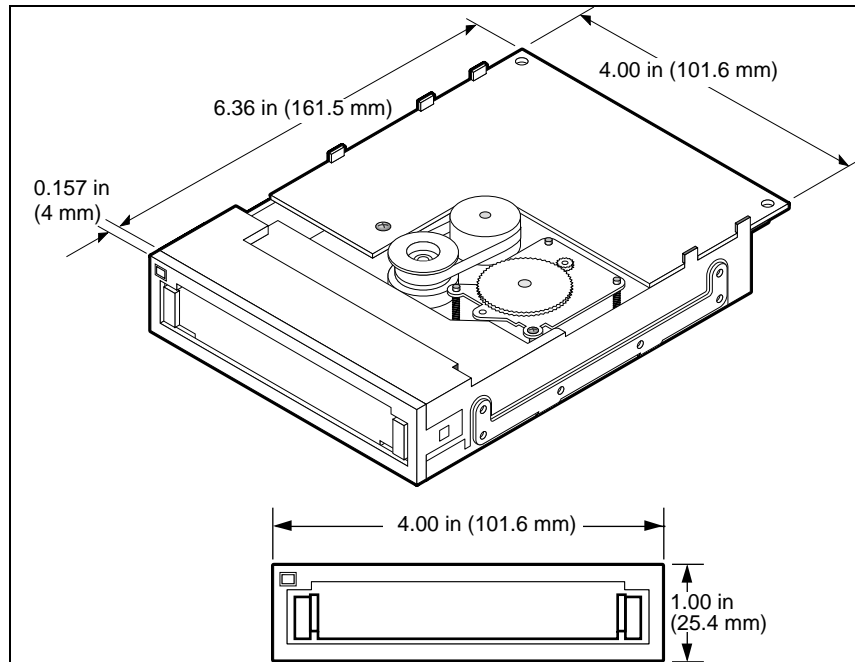
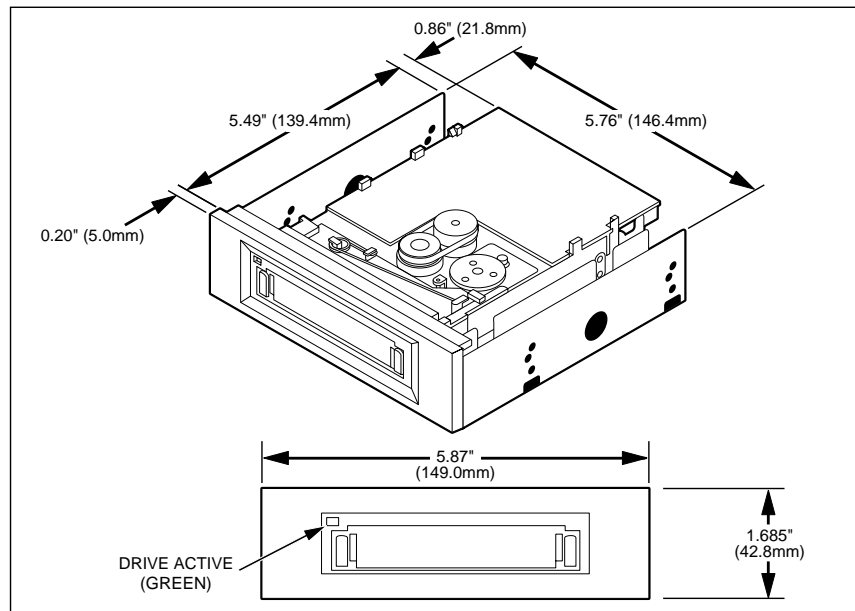

Figure 2-2
STT20000A (5.25-Inch mount) general dimensions



Power specifications

The following table lists the power specifications for the STT20000A. (Power specifications are measured at the tape drive power connector and are nominal values.)

<i>Specification</i>	<i>Measurement</i>	
DC Voltage	+12 VDC	+5 VDC
Voltage Tolerance	± 10%	± 5%
Operational Current	2.0 amps	1.0 amp
Standby Current	0.2 amp	0.6 amp
Peak	2.2 amps max.	—
Power Sequence	None	None
Ripple (peak to peak)	≤ 100 mV	≤ 100 mV
Power use (nominal)	< 15 Watts (excluding surge)	< 15 Watts (excluding surge)

The following table lists pin assignments for the power connector for the drive.

<i>Pin</i>	<i>Assignment</i>
1	+12 VDC
2	+12 return
3	+5 return
4	+5 VDC

Performance specifications

The following table lists the performance specifications for the STT20000A.

Feature	Specification
Capacity	10.0 gigabytes—1650 Oe 740' Travan cartridge (uncompressed) 20.0 gigabytes—1650 Oe 740' Travan cartridge (compressed)
Effective backup rate	up to 60 Mbytes/min native; up to 120 Mbytes /min compressed
Data transfer rate	489 / 733 / 1,000 Kbytes per second <i>FastSense</i>
Tape speed	
Read/Write	46, 70, or 94 ips
Search/Rewind	90 ips maximum
Recording method	Serpentine
Recording format	QIC-3220-MC
Recording code	1,7 RLL
Error recovery	Reed Solomon ECC
Recording unrecoverable errors	Less than 1 in 10 ¹⁵ data bits
Head configuration	Wide write/narrow read
Recording media	1650-Oe 740' Travan TR-5
Cartridge size	3.2 in. x 2.4 in. x 0.4 in. (81 mm x 61 mm)
Data density	100,400 bits per inch
Tracks	107 data tracks, one (1) directory track

Environmental requirements

The following table lists the environmental specifications for the STT20000A. The drive may be mounted either vertically or horizontally.

Specification	Operational	Non-operational
Temperature	+41° to +113° F ¹ (+ 5° to + 45° C)	–40° to +149°F ² (–40° to + 65°C)
Thermal gradient	1° C per minute (no condensation)	20° C per hour
Relative humidity	20% to 80% non-condensing ¹	5% to 95% non-condensing ²
Maximum wet bulb temperature	78.8° F (26° C)	No condensation
Altitude	–1000 to +15,000 feet	–1000 to +50,000 feet
Vibration		
Peak to Peak Displacement	0.005 in. max. (5 to 44.3 Hz)	0.1 in. max. (5 to 17 Hz)
Peak Acceleration	0.50 g max. (44.3 to 500 Hz)	1.5 g max. (17 to 500 Hz)
Acoustic level operational (A-wt sum)	55 dBA maximum (measured in suitable enclosure at 3-ft distance and operator height)	—
Shock (1/2 sine wave)	2.5 g's peak, 11 msec	100 g's peak, 11 msec

¹Specification applies to drive mechanism and media

²Specification applies to drive mechanism only

Reliability

The STT20000A is designed for maximum reliability and data integrity. The following table summarizes the reliability specifications.

Feature	Specification
Non-recoverable error rate	< 1 in 10 ¹⁵ bits
Error recovery and control	Reed-Solomon Error Correction Code techniques
	Error monitoring and reporting (Error Log)
	Media pre-written
	Retry on read
	Data randomization
Mean-Time-Between-Failures (MTBF)	More than 250,000 hours
Mean-Time-To-Repair (MTTR)	Less than 0.33 hour

Mean-Time-Between Failures

The Mean-Time-Between Failures (MTBF) is greater than 200,000 hours. This specification includes all power-on and operational time but excludes maintenance periods. Operational time is assumed to be 20% of the power-on time. Operational time is the time the tape is loaded.

Note: Seagate does not warrant the stated MTBF as representative of any particular unit installed for customer use. The failure rate quoted here is derived from a large database of test samples. Actual rates may vary from unit to unit.

Mean-Time-To-Repair

The Mean-Time-To-Repair (MTTR) is the average time required by a qualified service technician to diagnose a defective drive and install a replacement drive. The MTTR for the drive is less than 0.33 hour (20 minutes).

The STT20000A is a field replaceable unit. If a problem occurs with a subassembly or component in the drive, the entire unit should be replaced. The faulty drive should be returned to the factory in its original packaging. Contact your distributor, dealer, your computer system company, or your Seagate sales representative to arrange the return.

Recommended tapes

The STT20000A uses pre-formatted minicartridges. The following cartridges are recommended:

<i>Description</i>	<i>Seagate</i>	<i>3M/Imation</i>
Travan—740 ft (QIC-3220-MC) 10.0 GB capacity (20.0 GB capacity with data compression)	20000TT	TR-5

Note. The STT20000A reads and writes the QIC-3220-MC format.
The STT20000A reads (but does not write) the QIC-3095-MC format.

Regulatory compliance

The STT20000A complies with the regulations listed in the following table.

<i>Agency</i>	<i>Regulation</i>
CSA	C22.2, No. 950-M89
TUV & IEC-RHEINLAND	EN 60 950/IEC 950
UL	1950
Canadian Dept. of Communications	Class B
EN55022 (CISPR-22) with additional CE-Mark test requirements	Class B
FCC	Class B, Part 15

Use the STT20000A only in equipment where the combination has been determined to be suitable by an appropriate certification organization (for example, Underwriters Laboratories Inc. or the Canadian Standards Association in North America). You should also consider the following safety points.

- Install the drive in an enclosure that limits the user's access to live parts, gives adequate system stability, and provides the necessary grounding for the drive.
- Provide the correct voltages (+5 VDC and +12 VDC) based on the regulation applied—Extra Low Voltage (SELV) for UL and CSA and Safety Extra Low Voltage for BSI and VDE (if applicable).

Notes

Installation

3

Introduction

This chapter explains how to install the STT20000A. The following paragraphs briefly outline the organization of this chapter.

- The following section, **Before you begin** contains general information that you should read before you begin the installation.
- **Setting jumpers** shows the master/slave jumpers and describes their uses.
- **Installing the drive** explains how to mount the internal drive unit.

Before you begin

Handling guidelines

Because the drive unit can be damaged by electrostatic discharge, an electrostatic grounding strap is recommended. This strap prevents an electrostatic discharge from damaging the electronic components on or in the drive unit

If you do not have an electrostatic grounding strap, perform the installation at a static-safe workstation. If one is not available, follow these guidelines as you install the drive unit:

- Work in an uncarpeted area.
- To protect the drive from static electricity, DO NOT remove the drive from its anti-static bag until you are ready to install it.
- Before you remove the drive from the anti-static bag, touch a metal or grounded surface to discharge any static electricity buildup from your body.

Caution: If you touch static-sensitive parts of the drive (such as the printed circuit board) electronic components may be damaged.
--

- Hold the drive by the edges only. Avoid direct contact with any printed circuit board.
- Lay the drive only on top of its anti-static bag or return the drive to its bag when you need to lay the drive down.

Caution: If you substitute an ATAPI adapter card or longer cables, or if you chain the tape drive to an existing ATAPI adapter or peripheral, the compatibility and/or operation of the tape subsystem may be seriously affected.
--

Setting jumpers

Review the jumper settings to ensure that the jumpers are properly configured for your system. Figure 3-1 shows the location of the jumper block. Figure 3-2 shows the jumper block.

Note: Record your jumper settings prior to installation. They are not visible after the drive has been installed.

The default setting is Slave mode with a jumper over pin 3 and pin 4.

Your system setting may vary, so be sure to check your computer or ATAPI controller manual to determine the proper configuration choice for your system.

Figure 3-1
Location of jumper block and connectors

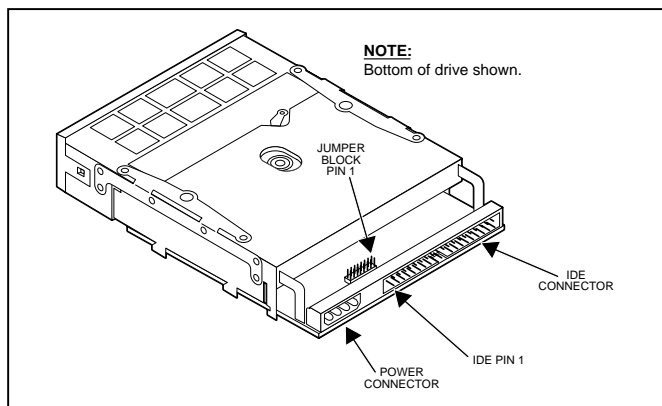
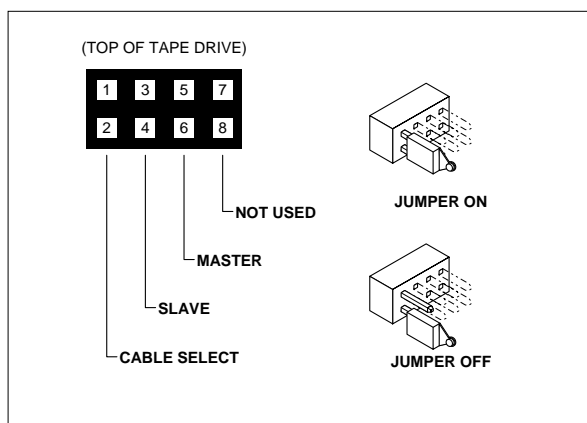

Figure 3-2
Jumper block and jumper settings



Installing the drive

The internal drive can be installed in a one-half-inch high by 3.5-inch form factor drive bay or in an inch-high by 5.25-inch form factor (with mounting brackets). The drive can be installed in three different orientations: horizontally (LED to the left) and vertically (on either side).

The following section provides directions for mounting the drive in either a 3.5-inch enclosure or in a 5.25-inch enclosure.

1. Before you install the drive, write down the serial number and model number shown on the drive and put this information in a safe place. You need this information if you ever call for service.
2. With the computer cover removed, remove the face plate from the drive bay in which you plan to install the drive. Refer to the manual that you received with your computer for instructions about removing the face plate if necessary.

Note: If devices are installed in any drive bays adjacent to the one you are using for the internal drive, partially removing those devices might give you more working space.

3. Attach any special mounting hardware to the drive that your system might require. Refer to the manual that you received with your computer for requirements.
4. Locate the mounting screw holes in the drive brackets. Each side contains two sets of holes. Use the set that aligns the drive properly within the drive bay.
5. Slide the tape drive into the computer so that the drive bezel and the computer face plate are flush. Then, align the mounting holes as shown in Figure 3-3.

Figure 3-3
Aligning the drive in the computer

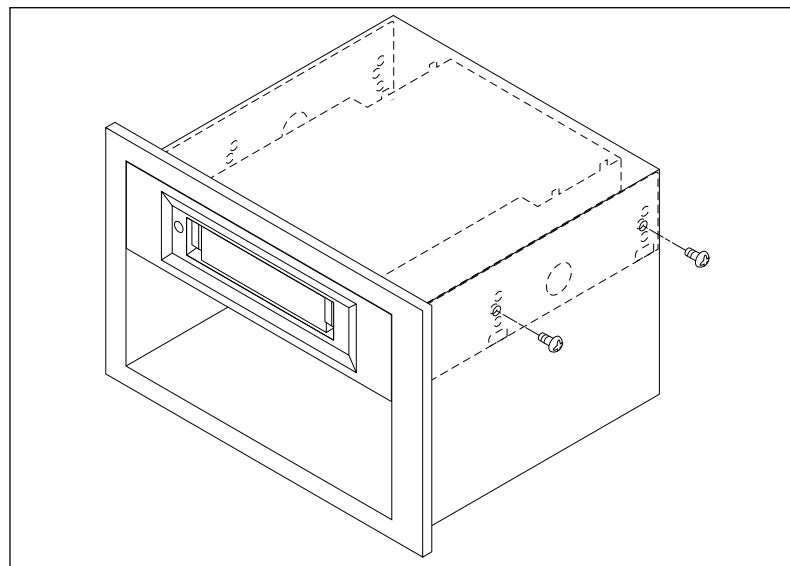

6. Secure the drive using the mounting screws. The threaded mounting brackets are designed for M3.0 metric screws. If you are mounting the drive in a 3.5-inch bay, use the screw supplied with the drive. Do not substitute other screws. Using longer screws may damage the drive. If slide rails are needed, use the plastic slide rails (supplied with the drive in some configurations).
7. Connect an available power cable to the power connector on the drive. Figure 3-1 shows the location of the power connector. The recommended power mating connector requires an AMP 1-48024-0 housing with AMP 60617-1 pins or equivalent.

Note: Turn off all power before inserting connectors.

8. Connect the interface cable with the connector on the rear of the unit. When you make the connection, be sure pin 1 of the connector aligns with pin 1 on the cable connector. See Figure 3-1 for the location of the connector and the Pin 1 location.

Note: Pin 1 on the connector on the rear of the drive is to your right as you look at the back of the drive (right side up). (See Figure 3-1.) Your cable should have Pin 1 highlighted by a color or dark strip. Be sure to mate Pin 1 on the cable to Pin 1 on the drive. Failure to do so could make the drive inoperative. Also, the cable is keyed to prevent incorrect installation. Make sure that the blocked pin in the cable connector coincides with the missing pin on the connector on the rear of the drive. (See Figure 3-1.)

9. Replace the computer cover. Be sure to reconnect any peripherals that you disconnected during the installation.
10. Plug the computer and any peripherals into an AC power outlet.
11. Start the computer and install your tape backup software.

Mounting dimensions

Figures 3-4 and 3-5, respectively, show the location of the mounting holes for the internal drive without and with mounting brackets.

Figure 3-4
Mounting holes on internal drive (without mounting brackets)

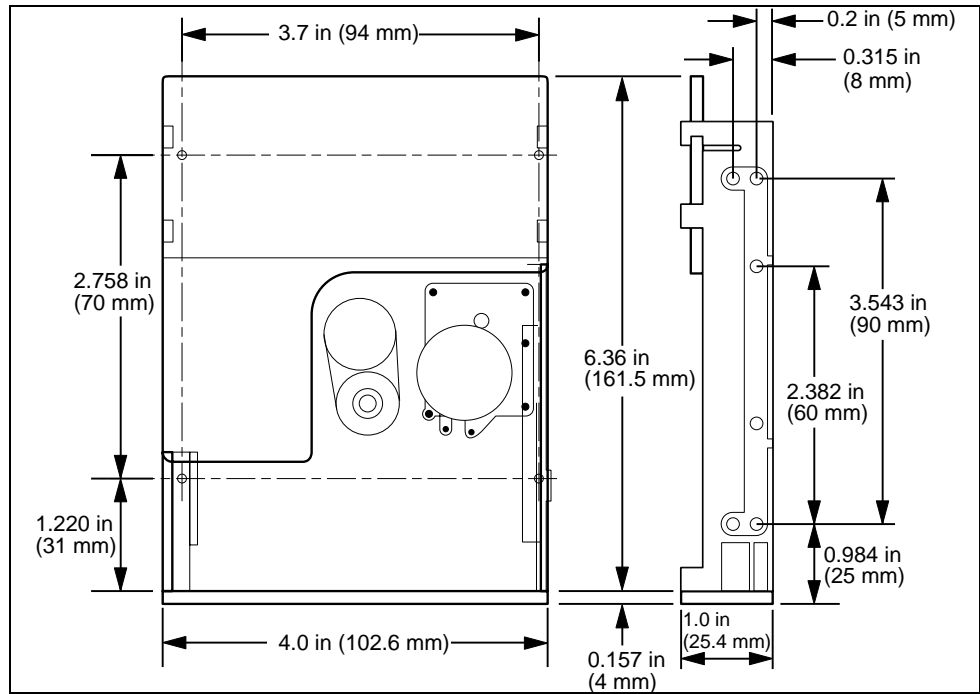
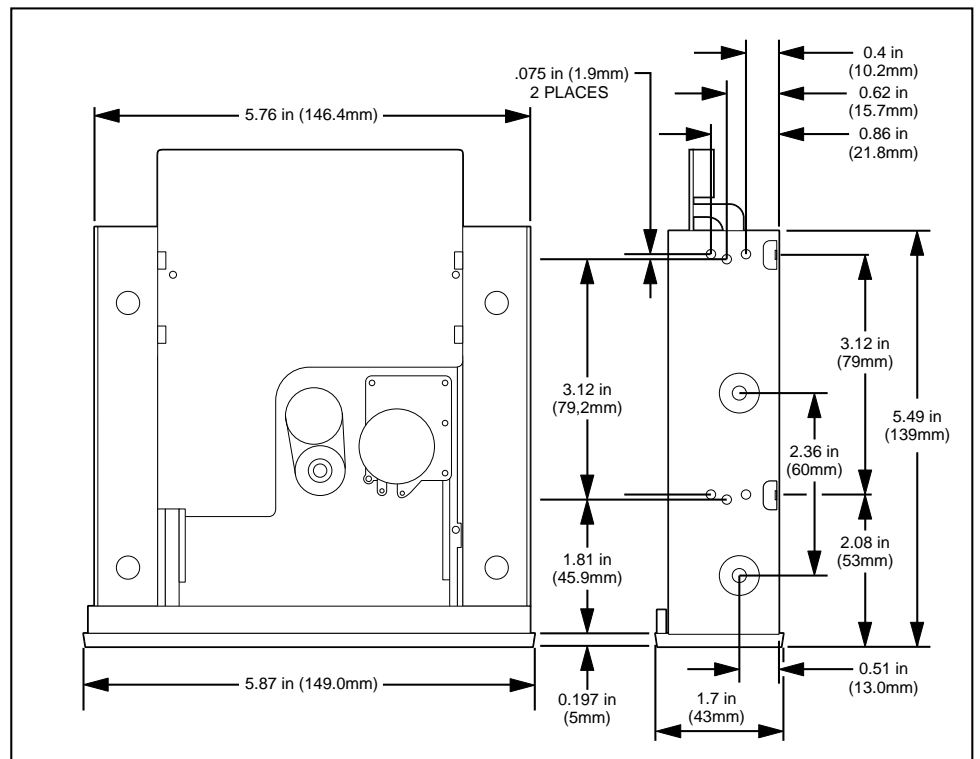

Figure 3-5
Mounting holes on internal drive (with mounting brackets)



ATA-2 Interface pin assignments

The STT20000A provides a standard ATA-2 connector. The pin assignments for this connector are listed in the following table for your reference.

<i>Pin</i>	<i>Assignment</i>	<i>Description</i>	<i>Source</i>
1	RESET	Reset	Host
2	Gnd	Ground	N/A
3	DD7	Data Bus bit 7	Host/Device
4	DD8	Data Bus bit 8	Host/Device
5	DD6	Data Bus bit 66	Host/Device
6	DD9	Data Bus bit 9	Host/Device
7	DD5	Data Bus bit 6	Host/Device
8	DD10	Data Bus bit 10	Host/Device
9	DD4	Data Bus bit 4	Host/Device
10	DD11	Data Bus bit 11	Host/Device
11	DD3	Data Bus bit 3	Host/Device
12	DD12	Data Bus bit 12	Host/Device
13	DD2	Data Bus bit 2	Host/Device
14	DD13	Data Bus bit 13	Host/Device
15	DD1	Data Bus bit 1	Host/Device
16	DD14	Data Bus bit 14	Baby sitting
17	DD0	Data Bus bit 0	Baby sitting
18	DD15	Data Bus bit 15	Host/Device
19	GND	Ground	N/A
20	---	Key pin	N/A
21	DMARQ	DMA Request	Device
22	GND	Ground	N/A
23	DIOW-	I/O Write	Host

Pin	Assignment	Description	Source
24	-REQ	Ground	N/A
25	-I/O	I/O Read	Host
26	GND	Ground	N/A
27	IORDY	I/O Ready	Device
28	CSEL	Cable Select	Device
29	DMACK	DMA Acknowledge	Host
30	GND	Ground	N/A
31	INTRQ	Interrupt Request	Device
32	10CS16-	16-Bit I/O	Device
33	DA1	Device Address Bit 1	Host
34	PDIAG	Passed Diagnostics	Device
35	DA0	Device Address Bit 0	Host
36	DA2	Device Address Bit 2	Host
37	CS0-	Chip Select 0	Host
38	CD1-	Chip Select 1	Host
39	DASP-	Device Active or Slave Present	Device
40	Ground	Ground	N/A

Notes

Drive operation and maintenance

4

Introduction

This chapter describes important operational procedures for the STT20000A. It covers the following topics:

- Use of the front panel LED
- Using cartridges
- Loading revised firmware (updating flash EEPROM)
- Drive maintenance and troubleshooting instructions.

Front panel LED

The front panel of the Travan drive (see Figure 4-1) contains the cartridge opening and one amber light-emitting diode (LED). This LED is lit any time that the tape is NOT at the beginning of the tape. Thus, the LED indicates tape movement.

Figure 4-1
Front panel—internal drive

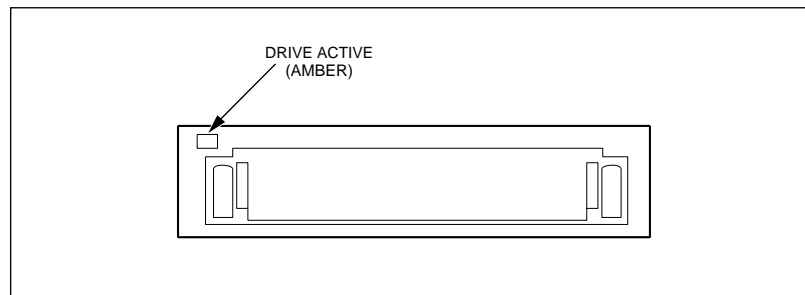

Using Travan cartridges

The minicartridges recommended for use with the STT20000A are listed in chapter 2. This section describes some operations using the cartridges.

Loading and unloading cartridges

Your tape drive has a flip-up door that covers the cartridge opening when a tape cartridge is not installed in the drive. Once a cartridge is inserted, it is held firmly in place by the drive's positive locking mechanism.

Caution: **DO NOT** remove a tape cartridge while the drive is active. Complete any tape operations and wait until the amber LED is OFF before removing the cartridge.

To load a cartridge, insert it with the metal base plate down and the tape access door facing into the drive. Figure 4-2 illustrates the loading of a cartridge.

Figure 4-2
Loading a Travan cartridge

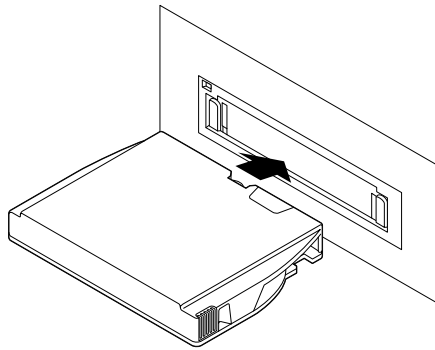

To unload a cartridge, wait until the drive activity LED is OFF and then pull the cartridge straight out. Figure 4-3 illustrates the unloading of a cartridge.

Figure 4-3
Unloading a Tape cartridge

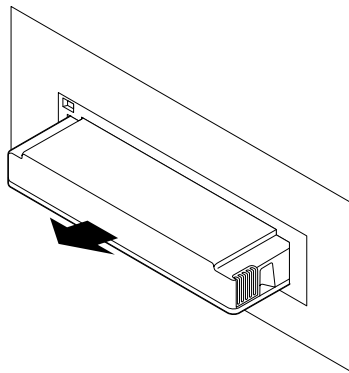

Setting the write-protect switch

Travan minicartridges feature a sliding write protect tab located in the upper left corner of the cartridge. You can set the tab to keep data from being written on the tape. Use this switch when you want to make sure that important data on the tape will not be overwritten.

Figure 4-4 shows the cartridge with the switch in the non-protected (read/write) or unlocked position.

Figure 4-4
Travan cartridge write-protect switch—unlocked position

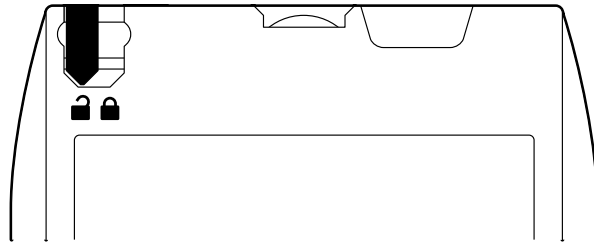
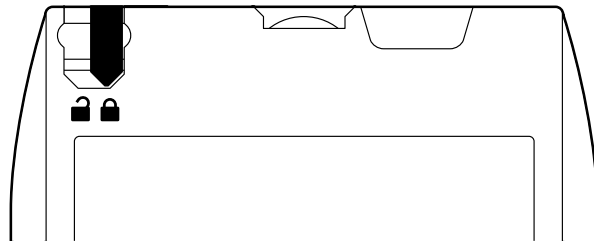

Figure 4-5 shows the tab in the protected (read only) or locked position.

Figure 4-5
Travan cartridge write-protect switch—locked position



To return a cartridge to the "writeable" state, push the switch toward the end of the cartridge or to the unlocked position.

Loading revised firmware via Seagate firmware cartridge

The STT20000A uses flash EEPROM. Flash EEPROM enables you to download new firmware when revisions to firmware are released. Firmware revisions are released on specially encoded cartridges that are automatically recognized by these drives. These firmware revisions are available for qualified OEMs only from Seagate Peripherals, Inc.

To load a firmware upgrade tape, follow these steps.

1. Power on the host system and the STT20000A drive. Allow the system boot up process to reach the point where there is no ATAPI bus activity.
2. Place the firmware upgrade cartridge record switch to the non-record position. Insert the firmware upgrade cartridge in the drive and observe the amber LED light on the front of the drive.
3. Once the upgrade cartridge is inserted, tape motion begins. The drive LED flashes on and off. Approximately 15 seconds later, tape motion stops, and the LED continues to flash.
4. The LED flashes on and off at a steady rate as the firmware upgrade continues. Approximately 45 seconds later, the drive resets internally, and the tape moves back and forth, then stops.
5. The LED light will go off and remain off. Double check that the LED remains off. Make sure that there is not further tape motion. Remove the upgrade cartridge.
6. The firmware is now upgraded to the new revision. The drive is operational and the new firmware is active. Turning power off at this time does not affect the firmware revision level.

Note: Once the firmware upgrade cartridge is inserted in the drive, it is important that no power interruption occurs while the firmware is loading. **DO NOT POWER OFF THE DRIVE AT THIS TIME.** If a power interruption occurs, the firmware may not be loaded correctly, and the drive may not operate properly.

If a problem occurs during the firmware loading process, the LED on the front panel goes out. In that case, the firmware upgrade cartridge may be defective, or the drive may not be operating correctly.

If after a repeat loading of the firmware cartridge, the same condition is observed, contact your Seagate sales representative.

Firmware upgrade cartridges are available to qualified Seagate OEM customers. Contact your Seagate sales representative for information.

Drive maintenance

Minimal maintenance is needed to ensure that your STT20000 SCSI minicartridge drive operates at peak condition. This section explains how to care for tape cartridges and how to clean the drive head.

Caring for tape cartridges

Although minicartridge tape cartridges are ruggedly built, they must be handled with care to preserve the data that they contain. The following points are guidelines for storing and using minicartridges.

- Do not open the tape access door of the cartridge or touch the tape itself. One fingerprint can prevent the drive from reading the tape.
- Keep the cartridge away from sources of electromagnetic fields, such as telephones, dictation equipment, mechanical or printing calculators, motors, and bulk erasers. Do not lay cartridges on the computer monitor or on the base unit of the computer.
- Keep the cartridge away from direct sunlight and heat sources, such as radiators or warm air ducts.
- Keep the cartridge free of moisture. Do not wet or submerge a cartridge in any liquid.
- Do not expose the cartridge to temperature extremes. Allow the cartridge to assume room temperature slowly.
- Retensioning the tape cartridge is always recommended for optimal performance, particularly after exposure of the cartridge to temperature changes or shock. Retensioning restores the proper tape tension to the media.

Cleaning the drive read/write head

<p>Caution. Never clean the read/write head of the drive with anything other than a lint-free swab or an approved cleaning cartridge. Do not touch the head with anything other than a lint-free swab.</p>

To properly maintain the tape drive, you should periodically clean the read/write head. No other periodic maintenance is required.

Follow these guidelines to help ensure that your drive provides long, reliable service:

- Operate the drive in a clean, dust-free environment.
- Never apply a lubricant to the drive.
- Generally Travan drives are highly reliable and require little user maintenance. For normal operations cleaning once per month is quite adequate.
- For new cartridges, clean the head after two hours of tape movement. Thereafter the drive can be cleaned as per normal operations.

You can clean the drive head by one of two methods: you can use the Seagate approved 3M DC2000 cleaning cartridge DC051111 (12947), P/N CKDC2000, which is available through Seagate Express 1-800-531-0968, or you can manually clean the drive head. To manually clean the drive head, follow these steps.

1. Moisten a clean, lint-free swab in 90% isopropyl alcohol so that it is wet but not dripping. (Never use a dry swab.)
2. Hold the drive access door open and wipe the head gently using a side-to-side motion. The upright rectangle with the stripe in Figure 4-6 is the head.

Figure 4-6
Cleaning the drive head and capstan

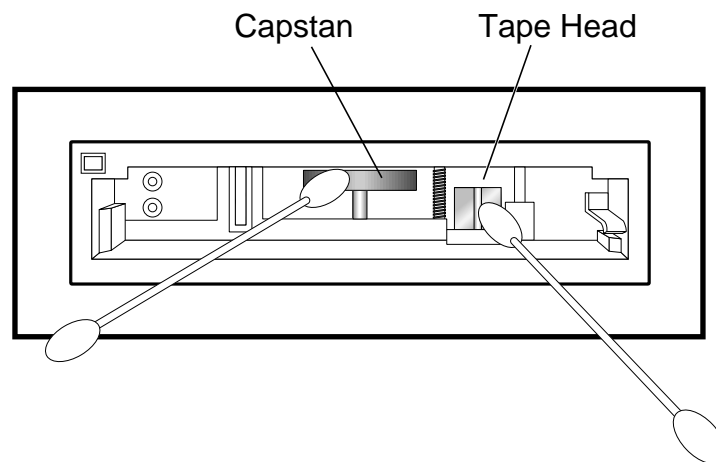

3. Use a new swab saturated with 90% isopropyl alcohol to wipe the capstan. The capstan is the flat, roller to the left of the head as shown in Figure 4-6. Rotate the capstan until its entire surface is clean.
4. Allow the drive to dry for 3 minutes before using.

Troubleshooting

If you experience problems after you install the drive, take the following actions to try to solve the problems.

- Check that all connections are secure.
- Check the drive to be sure that the jumper settings are correct.

If a power interruption occurs during a backup or restore operation, start over when the power is restored. If the drive appears to fail during a backup or restore operation, try the following steps:

1. Remove and replace the cartridge and try again. Make sure you are using the correct type of tape cartridge.
2. Turn off all power to the computer and drive. Wait for the computer to power down and then start over.

3. Try a different tape—preferably one that has never been used.
4. Check all cable connections for proper contact.
5. Clean the tape drive head as previously instructed. Then try the operation again.

If problems persist, contact your tape drive supplier or Seagate technical support at

US and Canada 1-800-SEAGATE (1-800-732-4283)

Outside US and Canada 1-405-936-1234

Seagate Web Site <http://www.seagate.com>

Seagate BBS 1-405-936-1630

Before you call technical support, be sure that you have the documentation for your computer and for all installed peripheral devices.

Notes

ATAPI interface

5

Introduction

The STT20000A provides an ATA Packet Interface (ATAPI) controller for communications between the host computer and the drive. The drive supports the QIC-157 standard interface.

The STT20000A provides a connection between the driver/card and the component of the PC. Refer to chapter 3 for specific cabling and connector information.

Note: Refer to the **QIC-157 Standard** for detailed information about the this interface.

This chapter clarifies the use of several ATA-2 signals and ATAPI commands that are either vague or optional in the QIC-157 specification.

ATA-2 Interface

The information about the ATA-2 interface is presented in the following topics: ATA-2 Signals, ATA Registers, and ATA Commands.

ATA-2 Signals

Only the DASP and PDIAG- signals are described in the following paragraphs.

DASP-

This signal is used during power-up handshake sequences for master/slave identification per ATA-2 specifications.

Because the device has its own front-panel activity LED, this signal is not driven by this device (to indicate activity) after power-up is complete.

PDIAG-

This signal is used during power-up handshake sequences for master/slave identification per ATA-2 specifications.

ATA registers

The following table lists the values for the registers during register initialization.

Register	POR	RESET– (Hard Reset)	ATA Reset (SRST Bit)	ATAPI Soft Reset	Read/Identify Device Cmds
STATUS	00h	00h	00h	10h	41h (DRDY+ERR)
ERROR	01h (No Error)	01h	01h	01h	04h (ABRT)
Sector Count (ATAPI Intr. Reason)	01h	01h	01h	01h	—
Sector Number (ATAPI Reserved)	01h	01h	01h	01h	—
Cylinder Low (ATAPI Byte Count High)	14h	14h	14h	14h	14h
Cylinder High (ATAPI Byte Count High)	EBh	EBh	EBh	EBh	EBh
Drive/Head	00	00	00	—	—

During an ATA soft reset or aborted ATA command, the host view of the DSC bit (Status register) will be cleared, along with the DRDY bit. Any ATAPI command including ATAPI Identify can be used to set DRDY true and to re-enable host view of DSC bit.

Status Register

The following layout represents the Status Register. The CORR and IDX bits are not used by the drive.

7	6	5	4	3	2	1	0
BSY	DRDY	- (0)	DSC	DRQ	CORR (0)	IDX (0)	CHECK

Bit	Mnemonic	Description
7	BSY	Busy—set when only drive has access to ATA registers.
6	DRDY	Drive Ready—set when DSC is valid.
4	DSC	Drive Seek Complete—set when drive ready for command.
3	DRQ	Data Request—set when data ready to be transferred.
0	CHECK	Check—set when an error has occurred.

Error Register

The following layout represents the Error Register.

7	6	5	4	3	2	1	0
Sense Key [3..0]				MCR	ABRT	EOM	ILI

Bit(s)	Mnemonic	Description
7-4	Sense Key	Set to indicate the reason for the CHECK bit being set in the Status Register.
3	MCR	Media Change Request—Always 0.
2	ABRT	Aborted Command—Set when an ATA or ATAPI command is aborted.
1	EOM	End Of Media—The end of the current partition was detected. On a WRITE command, unrecoverable data might be left in the buffer.
0	ILI	Illegal Length Indication—This bit is set when an illegal length block is read. Sense Status also indicates ILI.

Feature Register

The following layout represents the Feature Register.

7	6	5	4	3	2	1	0
.	DMA

Bit	Mnemonic	Description
0	DMA	DMA Data Transfer—When this bit is a 1, the data transfer is in DMA mode. If the bit is 0, PIO data transfer is used. All ATAPI packet commands are transferred in PIO mode.

The value in this register must be set before **every** ATAPI command that transfers data (including log/mode set/sense) to determine the transfer method. This register is overwritten by the drive after every command completion to present Error

information. If you do not program this register correctly, the drive "hangs" in the BSY state. To correct this problem, reset operations.

Supported ATA Commands

The ATA commands are briefly described in the following paragraphs.

Execute Drive Diags (90h)

This command is executed regardless of the state of the DRV bit. The command causes an actual microprocessor reset (drive loses all logical position information). Power-up diagnostics are performed, and the PDIAG/DASP handshake is performed per ATA-2 specification. The master device will generate an interrupt.

Idle Immediate (E1h)

This command causes the device to set its Power Mode state to Idle and to generate an interrupt. Although the drive has no actual power saving features, this command is emulated for software compatibility.

Standby Immediate (E0h)

This command causes the device to set its Power Mode state to Standby and to generate an interrupt. Although the drive has no actual power saving features, this command is emulated for software compatibility.

Check Power Mode (E5h)

This command causes the device to return its Power Mode state in the Int Reason register, and generate an interrupt. If the drive is in Standby mode, this command returns 00h in the Int Reason register, otherwise this command returns FFh in the Int Reason register (indicating IDLE mode).

Previous Cmd	Int Reason
Reset/Power-up	FFh (Idle)
Standby Immed.	00h (Standby)
Idle Immediate	FFh (Idle)
Any Other Cmd	FFh (Idle)

Sleep (E6h)

This command is treated as an Idle command and does NOT prevent the drive from responding to further commands.

Set Features (EFh)

If an unsupported feature is selected, the command is aborted. Otherwise, the indicated parameter is set. The following list indicates the supported features:

Feature Number	Set Feature Commands
03h	Set Transfer Mode from Sector Count register
66h	Disable reverting to power-on defaults (no-op)
CCh	Enable reverting to power-on defaults (no-op)

Set Transfer Mode Feature

If the Set Transfer Mode feature (03h) is received, the Sector Count (ATAPI Interrupt Reason) register is used to set the transfer mode based on the following table. Any transfer modes not listed in the table cause the command to be aborted.

Sector	Transfer Mode
00h	PIO Transfer Mode 4 (default)
01h	PIO Transfer Mode 2 (explicit IORDY disable)
08h	PIO Transfer Mode 0
09h	PIO Transfer Mode 1
0Ah	PIO Transfer Mode 2
0Bh	PIO Transfer Mode 3
0Ch	PIO Transfer Mode4
10h	Single Word DMA Mode 0
11h	Single Word DMA Mode 1
12h	Single Word DMA Mode 2
20h	Multi-word DMA Mode 0
21h	Multi-word DMA Mode 1
22h	Multi-word DMA Mode 2

Issuing PIO and DMA transfer modes does not actually select these operations; however, issuing these modes selects the rate of either type of transfer, as selected by the DMA bit (bit 0) of the ATAPI Features register.

ATAPI Identify Device (A1h)

The protocol and timing of this command conforms to a standard ATA type command as defined in ATA-2.

Note: This command is similar to the ATA Identify Device command except it uses a different op-code. The ATA Identify Device command is aborted.

This command is generally intended to be used by a low-level ATAPI driver to determine the number and type of ATA/ATAPI devices attached to the interface. This driver might be able to program transfer rates and other parameters in the host ATA (IDE) interface.

The following table defines the values returned by the drive.

Word	Description	Value	Meaning
0	General Configuration	81C0h	ATAPI Streaming Tape, Removable Accelerated DRQ, 12 byte packets
1-3	Disk info: cylinders, heads	0000h	Unsupported
4-6	Disk info: track, sector sizes	0000h	Unsupported
7-9	Reserved	0000h	—
10-19	Serial Number (20 ASCII characters)	"N...N"	Serial Number
20	Buffer Type	4002h	Cap & Mech Sts bytes 6 and 7
21	Buffer Size	02D8h	14 frames of 52 data blocks=728
22	ECC Bytes Available	0000h	Unsupported
23-26	Firmware Revision (8 ASCII characters)	"N.NN"	Firmware Revision
27-46	Model Number (40 ASCII characters)		Model Number. "Seagate STT20000A"
47,48	Disk info: mult-xfer, double word I/O	0000h	Unsupported
49	Capabilities	0F00h	IORDY supported. Logical Blocks Addressing and DMA supported
50	Reserved	0000h	—
51	PIO Data Transfer Cycle Timing	0200h	Mode 2
52	DMA Data Transfer Cycle Timing	0200h	Mode 2

Word	Description	Value	Meaning
53	Field Validity	0002h	Fields 54-58 not valid. Fields 64-70 valid
54-56	Current Cylinder/Heads/Sectors	0000h	Unsupported
57-58	Current Capacity	0000h	Unsupported
59	Reserved	0000h	—
60-61	User Addressable Sectors	0000h	Unsupported
62	Single Word DMA Mode	0407h	Selected DMA mode 2 (Upper Byte), DMA modes 2,1,0 Supported.
63	Multi Word DMA Mode	0407h	Selected DMA mode 2 (Upper Byte) DMA modes 2, 1, 0 supported.
64	Enhanced PIO Mode	0003h	PIO Mode 3 and 4 Supported
65	Minimum Multi Word DMA Cycle Time	0078h	Mode 2 (120 nanoseconds)
66	Recommended Multi Word DMA Cycle Time	0078h	Mode 2 (120 nanoseconds)
67	Minimum PIO Cycle Time w/o IORDY	0078h	Mode 4 (120 nanoseconds)
68	Minimum PIO Cycle Time with IORDY	0078h	Mode 4 (120 nanoseconds)
69-255	Reserved/Vendor Unique	0000h	—

ATAPI Packet Command (A0h)

Before issuing the ATAPI Packet command, the host writes to the Byte Count register (high and low) the maximum/preferred number of bytes to be transferred in a single PIO DRQ. For Data Transfer commands (READ and WRITE), this value is assumed to be greater than or equal to 512 and is ignored.

ATAPI Soft Reset (08h)

The ATAPI Soft Reset command performs a complete microprocessor reset. Current physical and logical position is lost, and if a tape is present, a LOAD sequence is performed, resulting in a Ready at BOP0 condition (with Unit Attn).

The DSC is set to 1 before the BSY bit is cleared.

ATAPI interface

The following table lists the ATAPI interface commands for the drive. In this table, DSC restrictive means that the host should wait for DSC to be set before issuing the command for minimum IDE bus overhead. Note that all ATAPI commands are 12 bytes in length. The command descriptions show only the first 6 or 10 bytes of these commands, even though the commands are actually 12 bytes long.

Code	DSC Restrictive	Command	Comments
00h	Y	TEST UNIT READY	Not DSC restrictive on some other drives.
01h	Y	REWIND	
03h	N	REQUEST SENSE	Null status if DSC not set.
08h	buffer	READ	Delay occurs if first READ is not READ 0 blocks.
0Ah	buffer	WRITE	Write 0 not required to initialize DSC.
10h	Y	WRITE FILEMARK	Flush always. WFM 0 to flush.
11h	Y	SPACE	Space forward/reverse Filemarks and space to EOD only.
12h	N	INQUIRY	DSC not affected.
15h	—	MODE SELECT	Select speed, FDP, page 2B updates only.
19h	Y	ERASE	Constitutes a logical erase; accepted at BOP0/1 or EOD only.
1Ah	—	MODE SENSE	
1Bh	Y	LOAD/UNLOAD	UNLOAD to make not ready; LOAD to return to Ready. LOAD w/Retension any time. (All LOADS imply REWIND and select partition 0.)
2Bh	Y	LOCATE	Locates logically only; can also select partition.
34h	Y	READ POSITION	Also used to wait for previous command done.
3Bh	—	WRITE BUFFER	Use for download only. Drive must be "unloaded".

4Ch	—	LOG SELECT	Resets Error Counts.
4Dh	—	LOG SENSE	Contains Error Counts (WRITE and READ) and tape capacity.

Reserved Fields

Unless otherwise stated, all reserved and unsupported fields are not verified when the drive accepts a command. These fields are filled with 00s for future compatibility.

Erase command

Bit=>	7	6	5	4	3	2	1	0
Byte								
0	Operation code (19h)							
1	Reserved							1 (Long)
2	Reserved							
3	Reserved							
4	Reserved							
5	Reserved							

The Erase command is only accepted when the drive is ready and located at either BOP 0/1 or EOD. Erase at BOP causes the drive to write a Control/Filler Frame at the beginning of the current partition, followed by an EOD pattern. (The Use Count field of the Control Frame is incremented from its previous value). This action results in a logical erasure of the current partition. If partition 0 is erased, partition 1 becomes logically erased because of the use count field. Erase at EOD is accepted, but no operation is performed except a write flush if following a WRITE command. This result is because all data following EOD is already logically erased.

The DSC bit is reset (0) after this command is accepted and is set (1) when the command is complete. REQUEST SENSE can then be used to verify successful command completion.

Inquiry command

Bit	7	6	5	4	3	2	1	0
Byte								
0	Operation code (12h)							
1	Reserved							
2	Reserved							
3	Reserved							
4-7	Allocation Length							
8-15	Vendor ID (8 ASCII characters) ASCII "Seagate "							
16-31	Product ID (16 ASCII characters ASCII "STT20000A "							

The INQUIRY command is always accepted, regardless of the state of the DSC bit. The command does not modify the status of DSC. The INQUIRY command returns the lesser of 36 bytes or the Allocation Length parameter of information. The following table defines the returned values.

Note: Much of the information returned by this command is redundant with the ATAPI Identify Device command response.

Byte	Description	Value	Meaning
0	Peripheral Device Type	01h	Streaming Tape Drive (QIC-121 Architectural Model)
1	Removable Media Bit (RMB)	80h	Removable
2	ISO/ECMA/ANSI Version	02h	ANSI=02
3	Response Data Format	02h	This Format
4	Additional Length	32.	36 total bytes
5-7	Reserved	00h	—
8-15	Vendor ID (8 ASCII characters)	ASCII	"Seagate "
16-31	Product ID (16 ASCII characters)	ASCII	"STT20000A "
32-35	Product Revision (4 ASCII characters)	ASCII	"N.NN"

The INQUIRY command is not to be used by the low-level driver; rather, it is intended to be used by applications, which usually have access to the drive only through the ATAPI protocol.

Load/Unload command

Bit	7	6	5	4	3	2	1	0
Byte								
0	Operation code (1Bh)							
1	Reserved							
2	Reserved							
3	Reserved							
4	Reserved						Re-Ten	Load
5	Reserved							

LOAD (with or without Re-tension) is accepted any time a tape is present in the drive, (even if status indicates it is already loaded). This command includes implicit rewind and select partition 0 operations. The DSC bit is reset (0) after this command is accepted and is set (1) when the drive has initialized and is ready. REQUEST SENSE can then be used to verify successful command completion.

The UNLOAD option(s) re-tensions the tape (if selected) and moves the tape to the logical BOT or EOT end (as selected), then causes the drive to report not ready to any subsequent media access commands. Either a manual load operation or LOAD command is required for the drive to return to ready.

Locate command

Bit	7	6	5	4	3	2	1	0
Byte								
0	Operation code (2Bh)							
1	Reserved						CP	Reserved
2	Reserved							
3	(MSB)							
4	Logical Block Address							
5								
6	(LSB)							
7	Reserved							
8	Partition							
9	Reserved							

If the Change Partition (CP) bit is set, the drive first changes to the specified partition, then attempts to locate before the specified logical block. (All addresses are interpreted as logical.) A locate to Block 0 (in any partition) is treated like a rewind (to BOP) and does not start a read-ahead. Depending on the exact sequence of commands, LOCATE to Block 0 might or might not report a Blank Check error.

The DSC bit is reset (0) after this command is accepted and is set (1) when completed. REQUEST SENSE can then be used to verify successful command completion.

Log Select command

Bit	7	6	5	4	3	2	1	0	
0	Operation code (4Ch)								
1	Reserved						PCR	Reserved	
2	01(PC)		Reserved						
3	Reserved								
4	Reserved								
5	Reserved								
6	Reserved								
7	(MSB)	Parameter List Length							
8								(LSB)	
9	Reserved								

The PC (Page Control) field is 01, for current values. The Parameter List Length field specifies the number of data bytes to transfer. If the PCR bit is 1 and the Parameter List Length is 0, the error counters are all reset (0).

All of the counters defined in the Log Sense command are reset by the Log Select command and are otherwise only cleared by a power-on (hard) or ATAPI reset.

Log Sense command

Bit	7	6	5	4	3	2	1	0
Byte								
0	Operation code (4Dh)							
1	Reserved							
2	01(PC)		Page Code					
3	Reserved							
4	Reserved							
5	(MSB)		Parameter Pointer					
6							(LSB)	
7	(MSB)		Allocation Length					
8							(LSB)	
9	Reserved							

The PC (Page Control) field is 01, for current values. The Page Code field identifies which page of data is being requested. The Parameter Pointer field allows requested parameter data to begin from a specific parameter code. The Allocation Length field specifies the number of data bytes to transfer.

The following table presents the supported log pages.

Byte	Description	Value	Meaning
0	Page Code	00h	Supported Log Pages Page
1	Reserved	00h	-
2,3	Page Length	00,04h	4 Supported Pages
4	First Supported Page	00h	Supported Log Pages Page Code
5		03h	Error Counter (Read) Page Code
6		31h	Tape Capacity Page Code
7	Last Supported Page	00h	Filler

Error Counter Page (Read)

The following table presents the Error Counter Page layout.

Byte	Description	Value	Meaning
0	Page Code	03h	Error Counter (Read) Page
1	Reserved	00h	-
2,3	Page Length	0030h	48 Bytes Following
4,5	Parameter Code	0000h	ECC Corrections Code
6	Parameter Bits	40h	Device Controlled Counter
7	Parameter Length	04h	4-byte Counter
8-11	Number of ECC Corrections	N,N,N,N	Counter Value
12,13	Parameter Code	0001h	Read Retries Code
14	Parameter Bits	40h	Device Controlled Counter
15	Parameter Length	04h	4-byte Counter
16-19	Number of Retries	N,N,N,N	Counter Value
20,21	Parameter Code	8020h	Even Tracks ECC Corrections Code
22	Parameter Bits	40h	Device Controlled Counter
23	Parameter Length	04h	4-byte Counter
24-27	Even Tracks(reverse) ECC Corrections	N,N,N,N	Counter Value
28,29	Parameter Code	8021h	Odd Tracks ECC Corrections Code
30	Parameter Bits	40h	Device Controlled Counter
31	Parameter Length	04h	4-byte Counter
32-35	Odd Tracks (forward) ECC Corrections	N,N,N,N	Counter Value
36,37	Parameter Code	8022h	Even Tracks Read Retries Code
38	Parameter Bits	40h	Device Controlled Counter
39	Parameter Length	04h	4-byte Counter
40-43	Even Tracks (reverse) Read Retries	N,N,N,N	Counter Value
44,45	Parameter Code	8023h	Odd Tracks Read Retries Code

Byte	Description	Value	Meaning
46	Parameter Bits	40h	Device Controlled Counter
47	Parameter Length	04h	4-byte Counter
48-51	Odd Tracks (Forward) Read Retries	N,N,N,N	Counter Value

Tape Capacity Page Code

The following table presents the Tape Capacity Page layout.

Byte	Description	Value	Meaning
0	Page Code	31h	Tape Capacity Page
1	Reserved	00h	-
2,3	Page Length	00,20h	32 Bytes Following
4,5	Parameter Code	0001h	Remaining Capacity, Part 0 Code
6	Parameter Bits	40h	Device Controlled Counter
7	Parameter Length	04h	4-byte Counter
8-11	Remaining Capacity, Partition 0 Value	N,N,N,N	
12-15	Parameter: Code, Bits, Length	0002h, 40h,04h	Remaining Capacity, Part 1 Code
16-19	Remaining Capacity, Partition 1 Value	N,N,N,N	
20-23	Parameter: Code, Bits, Length	0003h, 40h,04h	Maximum Capacity, Part 0 Code
24-27	Maximum Capacity, Partition 0 Value	N,N,N,N	
28-31	Parameter: Code, Bits, Length	0004h, 40h,04h	Maximum Capacity, Part 1 Code
32-35	Maximum Capacity, Partition 1 Value	N,N,N,N	

The Remaining Capacity for non-current partitions shall be the same as the Maximum Capacity for that partition. Capacities are multiplied by 1024 to determine the number of bytes. These values are conservative estimates.

The Parameter bit, TSD (not shown), is zero implying that the drive can save parameters across resets, etc. Parameters are not saved but are re-computed correctly from any logical position, regardless of the previous states of the tape drive.

Mode Select command

Bit	7	6	5	4	3	2	1	0	
Byte									
0	Operation code (15h)								
1	Reserved			1 (PF)	Reserved				
2	Reserved								
3	(MSB)	Parameter List Length							
4								(LSB)	
5	Reserved								

The Mode Select command provides a means to change device parameters. The PF (Page Format) bit is 1, since the Mode Pages are in SCSI-2 format. The only changeable parameters are Speed Selection (in the Mode Parameter Header), and certain fields in Mode Page 2Bh (MFM mode). The Parameter List Length field specifies the length in bytes of the Mode Select parameter list that are transferred to the device as data. A Parameter List Length of zero indicates that no data is transferred.

Mode Sense should be issued prior to Mode Select to determine the supported pages, page lengths, and other parameters.

The device terminates the Mode Select command with a Check Condition status, sets the Sense Key to Illegal Request, and sets the Additional Sense Code to Invalid Field in Parameter List for the following conditions:

- If an attempt is made to change an unchangeable value in the Mode Select header, block descriptor, or any page.
- If an attempt is made to send a page with a length not equal to the parameter length reported for that page by the Mode Sense command.
- If an attempt is made to send a value for a parameter that is outside the range supported by the device.

Mode Sense command

Bit	7	6	5	4	3	2	1	0
Byte								
0	Operation code (1Ah)							
1	Reserved			DBD	Reserved			
2	00(PC)		Page Code					
3	(MSB) Allocation Length							
4	(LSB)							
5	Reserved							

The PC (Page Control) field is 00, since only current values are reported. If DBD (Disable Block Descriptor) is set (1), then the Mode Block Descriptor is not included in the data returned to the host. The Allocation Length field specifies the number of data bytes to transfer

The following pages are supported for Mode Select and Mode Sense commands.

Page Code	Description
11h	Medium Partition Page
2Ah	Capabilities and Mechanical Status Page
2Bh	Tape Parameters Page (MFM mode)
3Fh	Return All Pages

Mode Parameter Header

The following table describes the Mode Parameter header.

Byte	Description	Value	Meaning
0	Mode Data Length	NN	Select: Reserved Sense: Length of Available Following Data
1	Medium Type	NN	Tape type
2	Device Specific Parameters	WP,001,Speed	Bit 7 = Write Protect, Bits 6-4 = 001, Bits 3-0 = Speed Selection
3	Block Descriptor Length	00/08h	If 8, Block Descriptor follows

The only supported Buffered Mode (bits 6-4 of byte 2) is 001, indicating that write operations **are** buffered. Only the Speed Selection field can be changed.

The following table defines the tape speeds supported with QIC-3095 tapes.

Speed	Tape Speed	Transfer Rate
0000b	Automatic	Automatic
0001b	46 ips	489 Kbytes/sec
0010b	69 ips	733 Kbytes/sec
0011b	92 ips	1,000 Kbytes/sec

Mode Block Descriptor

The Block Descriptor is returned to the MODE SENSE command unless the DBD bit in the command packet is set to one. If the Block Descriptor is not sent, the Block Descriptor Length field (in the Mode Parameter Header) is 0.

Byte	Description	Value	Meaning
4	Density Code	NN	Current Density
5-7	Number of Blocks	000000h	Zero
8	Reserved	00h	—
9-11	Block Length	000200h	Always 512 byte blocks

The Number of Blocks is 0, indicating that all blocks in the media match this descriptor, (the blocks are fixed 512 byte blocks).

None of the Block Descriptor parameters may be changed (Block Length is fixed).

Mode Medium Partition Page

The following table describes the Mode Medium Partition Page layout.

Byte	Description	Value	Meaning
0	Page Code	11h	Medium Partition Page
1	Page Length	06h	6 Bytes of Information
2,3	Maximum Additional Partitions, Additional Partitions Defined	00h,00h	Not Supported
4	FDP (bit 7), reserved	80h	Fixed Data Partitions
5	Medium Format Recognition	03h	Format and Partition Recognition
6,7	Reserved	00h,00h	—

None of the Medium Partition Page (11h) parameters can be changed.

Mode Capabilities and Mechanical Status Page

The following table describes the Mode Capabilities and Mechanical Status Pages

.Byte	Description	Value	Meaning
0	Page Code	2Ah	Capabilities and Mechanical Status Page
1	Page Length	12h	18 Bytes of Information
2,3	Reserved	00h,00h	—
4	SPREV (bit 5), RO (bit 0)	20h	Space Reverse supported, bit 0 = Write Protect status
5	QFA (bit 5)	20h	QFA supported
6	ECC (bit 6)	40h	ECC supported
7	BLK1024 (bit 1), BLK512 (bit 0)	03h	512 byte blocks (1024 if floppy tape)
8,9	Maximum Speed Supported (Kbytes per second)	600.	1,000 Kbytes/sec Maximum
10,11	Maximum Stored Defect List Entries	0000h	—
12,13	Continuous Transfer Limit (blocks)	0034h	52 blocks per Read/Write command
14,15	Current Speed Selected (Kbytes per second)	NNNN	Current transfer rate
16,17	Buffer Size (in 512 bytes)	02D8h	14 frames of 52 blocks = 728

.Byte	Description	Value	Meaning
18-19	Reserved	00h	—

None of the Mode Capabilities and Mechanical Status Page (2Ah) parameters can be changed.

Mode Tape Parameters Page

Byte	Description	Value	Meaning
0	Page Code	2Bh	Tape Parameters Page
1	Page Length	0Eh	14 Bytes of Information
2	Density in Kilo bits per inch	NN	Density can imply tape format
3	Reserved	00h	—
4	Reserved (Format Fill Byte)	00h	Not used, MFM mode is read only
5	BSEG	20h	Number of Blocks per Segment (32)
6,7	SEGTRK	NNNN	Number of Segments per Track
8,9	TRKS	NN	Number of Tracks (per Tape)
10	MAXSECT	80h	Max MFM Sector Value (128)
11	MAXCYL	NN	Max MFM Cylinder Value
12	MAXHD	NN	Max MFM Head Value
13,14	Reserved	0000h	—
15	WDAM, RM, FW (bits 7-5)	00h	Not Used, MFM mode is read only

This page is used for MFM (Modified Frequency Modulation), or floppy interface tape formats, such as 2080, 2120, TR1, TR2, TR3, etc. This feature is not available in the STT20000A.

The following fields are changeable: SEGTRK, TRKS, MAXCYL, and MAXHD.

Read command

Bit	7	6	5	4	3	2	1	0
Byte								
0	Operation code (08h)							
1	Reserved							1 (Fixed)
2	(MSB)							
3	Transfer Length							
4	(LSB)							
5	Reserved							

The Transfer Length specifies the number of fixed 512 byte blocks to be transferred. A transfer length of 0 indicates that no data is to be transferred but will initiate a read-ahead.

The DSC bit is reset (0) after this command is accepted and is set (1) when at least 52 blocks in the buffer are available for the next READ command. Issuing a READ command when the DSC bit is reset (0) will keep the ATA bus busy (BSY = 1) while the drive is reading the required data into the buffer. This delay could be more than a minute if exhaustive retries are required to read the data.

Read Position command

Bit	7	6	5	4	3	2	1	0
Byte								
0	Operation code (34h)							
1	Reserved							
2	Reserved							
3	Reserved							
4	Reserved							
5	Reserved							
6	Reserved							
7	Reserved							
8	Reserved							
9	Reserved							

The following table describes the Read Position layout.

Byte	Description	Value	Meaning
0	BOP, EOP, BPU	nn	80h = Beginning of Partition 40h = End of Partition 04h = Block Position Unknown
1	Partition Number	00/01h	Current Partition (bit 0)
2,3	Reserved	00h	-
4-8	First Block Location (Host Block Location)	NNNNNNNN	Logical Number of next block to transfer between host and buffer
8-11	Last Block Location (Medium Block Location)	NNNNNNNN*	Not Supported
12	Reserved	00h	—
13-15	Blocks in Buffer	000000*	Not Supported

Byte	Description	Value	Meaning
16-19	Bytes in Buffer	00000000*	Not Supported

*These fields might appear to report the number of bytes/blocks in the buffer. However, this information is not guaranteed to be accurate. You should not rely on this information.

The only position that is guaranteed is the host logical block position. The First and Last Block Locations both return the same host location, and Blocks and Bytes in Buffer are reported as 0.

Because Read Position is DSC restrictive on all ATAPI tape drives, it can be used to “wait” for any previous command to complete. This can be useful for applications with ATAPI only access to determine the actual completion of a command. Note, this will keep the ATA bus busy during the “wait”. DSC polling (to wait for DSC set) is preferred when possible.

Request Sense command

Bit	7	6	5	4	3	2	1	0
Byte								
0	Operation code (03h)							
1	Reserved							
2	Reserved							
3	Reserved							
4	Allocation Length							
5	Reserved							

An Allocation Length value of 20 will return all Request Sense data.

The Request Sense command is always accepted, regardless of the state of the DSC bit, but the status is valid only when DSC or CHK (error) is set (1). If DSC and CHK are both reset (0), a non-error “null” status is returned. Normally, if CHK is set, DSC is set. The only time CHK is set and DSC is reset, is during writes at logical end of media; DSC remains a buffer indicator, and CHK is set to indicate EOM, which is a warning, not an error.

If a command completes with a check (error) condition, the next command issued, if not Request Sense or Inquiry, will be aborted, and a deferred error will be reported. If the command is Request Sense, a non-deferred error is reported. The Inquiry command does not affect status reporting.

The following table describes the REQUEST SENSE layout.

Byte	Description	Value	Meaning
0	Valid, Error Code	70h,71h	80h = Information Field Valid + 70h = Current Errors or 71h = Deferred Errors
1	Reserved (Segment Number)	00	—
2	Filemark, EOM, ILI, Sense Key	NN	80h = Filemark + 40h = EOM + 20h = ILI + Sense Key

3-6	Information	NNNNNNNN	Transfer Residue or Unwritten Blocks + Filemarks
7	Additional Sense Length	0Ah	10 bytes following
8-11	Command Specific Information	00h	Not Supported
12	Additional Sense Code (ASC)	NN	
13	Additional Sense Code Qualifier (ASCQ)	NN	
14	Field Replaceable Unit Code	00h	Not Supported
15	SKSV + Sense Key Specific	00h	Not Supported
16,17	Sense Key Specific	0000h	Not Supported
18,19	Pad	0000h	Pad to 4-byte boundary

Rewind command

Bit	7	6	5	4	3	2	1	0
Byte								
0	Operation code (01h)							
1	Reserved							
2	Reserved							
3	Reserved							
4	Reserved							
5	Reserved							

The Rewind command first ensures that all buffered write data has been transferred to the medium, then causes the device to position to BOP of the current partition.

The DSC bit is reset (0) after this command is accepted and is set (1) when the drive is ready to write at BOP0 (or encountered a hardware error). REQUEST SENSE can then be used to verify successful command completion.

Space command

Bit	7	6	5	4	3	2	1	0
Byte								
0	Operation code (11h)							
1	Reserved					Space Code		
2	(MSB)							
3	Count							
4	(LSB)							
5	Reserved							

The only Space codes that are supported are 001b (Filemarks) and 011b (End of Data on Current Partition). For Space Filemarks, negative count (2s compliment) indicates Space Filemarks Reverse.

The DSC bit is reset (0) after this command is accepted and is set (1) when the command is completed and the drive is ready. REQUEST SENSE can then be used to verify successful command completion.

Test Unit Ready command

Bit	7	6	5	4	3	2	1	0
Byte								
0	Operation code (00h)							
1	Reserved							
2	Reserved							
3	Reserved							
4	Reserved							
5	Reserved							

This command can be used to determine the readiness of the device to accept a media access command. It's purpose is to indicate the cartridge state: no cartridge (or drive fault), cartridge becoming ready, or cartridge/drive ready.

If the drive is busy with a previous command (DSC reset), the drive will wait for the previous operation to complete before releasing the ATA bus. On some other ATAPI tape drives, Test Unit Ready does not wait for DSC set before completing, and if an application needs to "wait" for an command done via the ATAPI interface, Read Position should be used instead.

Write command

Bit	7	6	5	4	3	2	1	0
Byte								
0	Operation code (0Ah)							
1	Reserved							1 (Fixed)
1	Reserved							
2	(MSB)							
3	Transfer Length							
4	(LSB)							
5	Reserved							

The Transfer Length specifies the number of fixed 512 byte blocks to be transferred. A transfer length of 0 indicates that no data is to be transferred but is used on some drives to put DSC into write buffer mode.

The DSC bit is reset (0) after this command is accepted and all data has been transferred. This bit is set (1) when there are at least 52 empty blocks in the buffer available for the next WRITE command. Issuing a WRITE command when the DSC bit is reset (0) will keep the ATA bus busy (BSY=1) until buffer

Write Filemark command

Bit	7	6	5	4	3	2	1	0
Byte								
0	Operation code (10h)							
1	Reserved							
2	Reserved							
3	Reserved							
4	Reserved							Count
5	Reserved							

After receiving this command, the device sets DSC (0) and returns completion status. Any data remaining in the buffer is then written to tape (flush/ synchronize), and if the count is 1, a Filemark is written. In any case, an EOD is then written.

The Immed bit in the command packet is ignored, and the DSC bit is reset (0) after this command is accepted. The DSC bit is set (1) after the EOD has been successfully written. REQUEST SENSE can then be used to verify successful command completion.

Write Buffer (download microcode) command

Bit	7	6	5	4	3	2	1	0
Byte								
0	Operation code (3Bh)							
1	Reserved					101 (Mode)		
2	Reserved							
3	Reserved							
4	Reserved							
5	Reserved							
6	(MSB)							
7	Transfer Length							
8	(LSB)							
9	Reserved							

The Write Buffer command is intended only to provide a method for downloading new drive microcode (firmware) into Flash EPROM, so the only valid MODE is 101 (download microcode and save). The drive must be Not Ready (unloaded) for this command to be accepted, and the transfer length is set to the download file size, which is currently 0x026800. All data is transferred in one command.

Tape format

6

Introduction

The STT20000A conforms to the QIC-3220-MC recording format standard. This format is for streaming magnetic tape in a minicartridge that is to be used for information interchange among information processing systems, communication systems, and associated equipment.

This chapter provides an overview of the tape format used by the STT20000A.

Tape partitioning

The drive uses factory pre-written Travan TR-5 media. The tape is always divided into two partitions:

- Partition 1 is the directory partition and is recorded on the Directory track only.
- Partition 0 contains the data (tracks 0 through 107) and is recorded on all tracks except the Directory track.

Recording data at 100,400 bits per inch (BPI), the drive can store 10.0 GB on the data partition of one 740-foot long, 0.315-inch (8.0 mm) wide Travan TR-5 tape. Using software data compression, these capabilities are typically doubled.

The recording format and partitioning support Quick File Access (QFA).

Track positions

The centermost track is called the Directory Track and has larger guard bands on both sides of it to allow it to be written without interfering with its adjacent tracks.

Track zero is the track immediately below the Directory Track. The even numbered tracks are positioned sequentially below track 0. Thus, track 2 is below track 0, and track 4 is below track 2, and so on down to track 70, which is the closest to the reference edge of the tape. (The reference edge is the edge of the tape that is nearest to the baseplate of the cartridge.)

Track 1 is the track immediately below the Directory Track. The odd numbered tracks are positioned sequentially up from track 1. Thus, track 3 is above track 1, and track 5 is above track 3, and so up to track 71, which is the closest to the upper edge of the tape.

Track numbering

All even numbered tracks, and the Directory Track, are recorded in the forward direction (the direction from the BOT marker to the EOT marker). All odd numbered tracks are recorded in the reverse direction (the direction from the EOT marker to the BOT marker). All even numbered tracks are located below the Directory Track; all odd numbered tracks are above it.

Track format

Tracks are recorded sequentially beginning with track 0, then track 1, and so on. Before recording, data are grouped into blocks, and blocks are grouped into frames with 128 blocks per frame.

Two numbering methods are used for blocks: physical numbering and logical numbering. Both numbers start from 0 at the beginning of each partition.

- Physical numbering is related directly to the recorded block on the tape. Each new block is given a unique physical number, regardless of its contents.
- Logical numbering does not relate to the blocks physically recorded on the tape; rather, this type of numbering is the block numbering system used by the host computer. Often the host system operates with logical blocks that are a different size from the 512-byte blocks that are physically recorded on the tape.

The host blocks can be larger or smaller than 512-bytes and can also be fixed or variable. Fixed host blocks contain the same number of data bytes in each block. Variable host blocks may contain a different number of data bytes in each block.

The format provides both a physical block number for each block recorded on the tape and a logical block number that can span more than one physical block. These two numbers are recorded in the control field of every block.

Frames

Every track on the tape is recorded in blocks that contain 512 data bytes. The data bytes are 8-bit bytes, which are numbered b0 to b7 with b7 being the most significant bit.

A frame is made up of 128 blocks—108 data blocks plus 20 error-correction code (ECC) blocks. Figure 6-1 illustrates the general track layout of sequentially recorded frames.

Figure 6-1
General track layout

Frame N	Frame N+1	Frame N+2	Frame N+3	Frame N+4	
---------	-----------	-----------	-----------	-----------	--

Frames are numbered indirectly using the 26 most significant bits of the Physical Block Address. Frame operation is controlled by the drive and generally invisible to the host. Frames are used primarily as a means to control the error correction operations.

Frames can be overwritten with new data frames or an end-of-data (EOD) frame. Append operations can only begin at EOD.

An underrun is not allowed in the middle of a frame, regardless of the frame type. Filler blocks can be used to complete a frame as long as they are not used interior to a logical block.

A frame that cannot be completed on one track is rewritten in its entirety at the beginning of the following track. Frames are not split around corner turns.

The general frame layout—108 data blocks and 20 ECC blocks—is illustrated in Figure 6-2.

Figure 6-2
General frame layout

Data Block 0	Data Block 1	Data Block 2	...	Data Block 107	ECC Block 0	ECC Block 1	...	ECC Block 19
--------------	--------------	--------------	-----	----------------	-------------	-------------	-----	--------------

The four types of frames are as follows:

- **Data frames** contain data and information blocks in addition to ECC blocks.
- The **Media Header frame** contains only Media Header blocks and ECC blocks. This frame is recorded as the first frame on the Directory Track.
- **Track ID frames** are recorded as part of the pre-formatting process of the cartridge. These frames are easily distinguished from other frame types because they reside entirely outside of the data region of the tape.
- An **EOD** frame is an absolute indicator of the end of the recorded data. It is recorded after the last frame containing host data upon terminating a Write process.

Blocks

Information in the Block Control byte determines the type of block being recorded except for ECC blocks which are recognized by their block numbers. Also, information about the number of user data bytes available in each data block is recorded in the Block Control byte of the block.

The Data Field of the blocks always contain 512 bytes. However, the number of valid data bytes in the block may be less than 512.

The seven different types of blocks are as follows:

- **Data blocks** contain user data. A full Data block contains 512 bytes; however, data block can contain from 1 through 511 valid data bytes depending on the selected logical block size of the host.
- **Media Header blocks** contain specific host., drive, and vendor information as well as the Volume Directory. The first frame on the Directory Track is the Media Header Frame. This frame contains 108 Media Header blocks (plus the normal 20 ECC blocks).
- **Information blocks**—Filemark blocks, Setmark blocks, and Cancelmark blocks—contain specific types of information. Filemark blocks are physical blocks written to tape in response to a host WRITE FILEMARKS command. Setmark blocks are physical blocks written to tape in response to a host WRITE SETMARKS command. Cancelmark blocks are physical blocks written to tape under firmware control.
- **Filler blocks** contain no valid information in the data area. These blocks are used to fill incomplete frames.
- **EOD blocks** are absolute indicators of the end of recorded data.
- **ECC blocks** contain error correction parity bytes that are used to ensure data integrity during read operations.
- **Track ID blocks** are recorded as part of the pre-formatting process of the cartridge.

Tape reference servo pattern

To increase track density, a track servo reference pattern is prerecorded on the tape at the factory. The pattern is recorded referenced to servo patterns in the region between the beginning-of-tape (BOT) hole and the load point market (LP) hole. The same pattern is recorded between the end-of-tape (EOT) hole and the early warning (EW) hole. The servo pattern is written across the entire width of the tape.

Write equalization

The drive uses the technique of write equalization. Write equalization inserts short pulses in the write current to break up the long spacing intervals. These pulses are too short to be detected in the read process but result in significant improvement in read-back resolution.

On 1650-Oersted media, write equalization provides the benefit of compatibility with Magneto-Resistive (MR) heads. MR heads are prone to saturation by low frequency flux with high energy content. Equalization redistributes this energy to higher frequencies and eliminates the problem.

Randomization

To reduce problems resulting from long strings of repetitive data with a bad peak shift or amplitude characteristics, a data randomizer algorithm is used on all bytes in the data and control area of each block. This randomizing takes place prior to the encoding of the data.

Notes

Theory of operations

7

Overview

The STT20000A is a low-cost, high-performance TR-5 minicartridge tape drive that is ideal for stand-alone users or small network computer systems. With capacities of 10.0 Gbytes to 20.0 Gbytes dependent upon media and data compression, this drive offers quick, efficient backup and restore operations. Its unique *FastSense™* feature automatically selects the appropriate transfer rate—1,000, 733, or 489 Kbytes/sec—based on the speed of the operating system.

The STT20000A is based on proven Seagate designs, Seagate firmware, and the latest technology. This drive uses second generation, custom LSIs for efficient circuit layout and increased reliability with low power consumption. The drive also uses flash EEPROM devices for easy firmware upgrades.

This chapter describes the drive in more detail and explains implementation specific information.

Block diagram

The electronics of the STT20000A are laid out on one main printed circuit board (PCB). Figure 7-1 shows a simplified block diagram of the drive.

Figure 7-1 Simplified block diagram for STT20000A

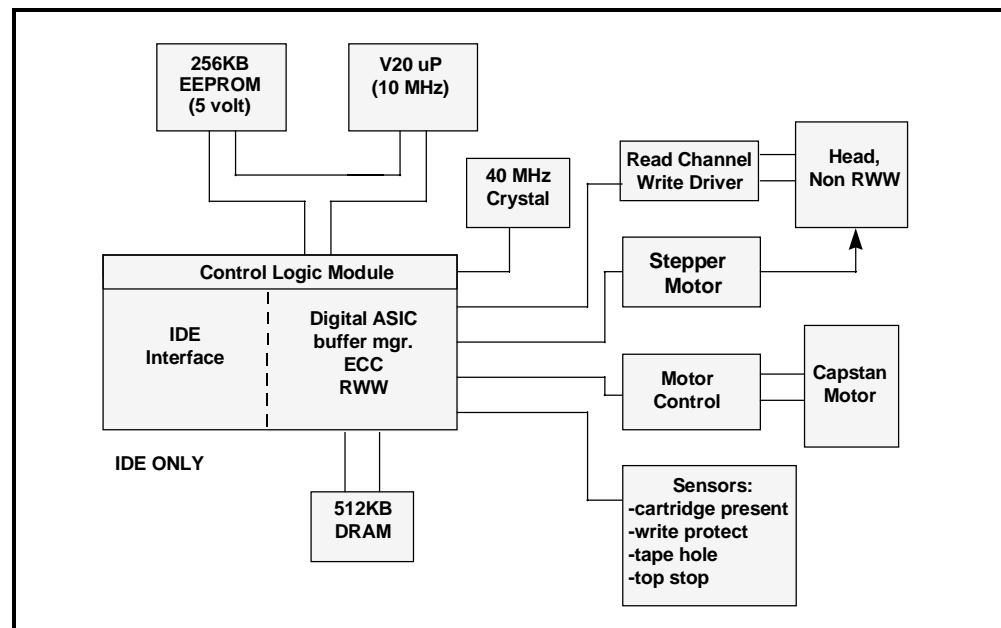

Drive mechanisms

This section generally describes the hardware design features of the STT20000A. You may want to refer to the block diagrams referenced previously as you read this information.

Mechanics

The mechanical package for the STT20000A was designed to provide you with all the advantages of easy cartridge loading and unloading while maintaining the positioning accuracy necessary for high-density data recording. The orientation of the cartridge is the same as the majority of QIC minicartridge drives in the field.

Cartridge-load mechanism

The cartridge is inserted in the drive by sliding it through the aperture in the bezel and into a tray mechanism. When fully inserted the back portion of the cartridge protrudes about 3/4-inch from the aperture. A switch is actuated at this point that causes a microprocessor to complete the loading operation.

When the tape is in motion, the amber LED on the front panel flashes. The LED is not lit when the tape is positioned at BOT.

Capstan/drive-motor assembly

In the STT20000A, the cartridge is driven by the capstan/belt motor assembly, which is on a linear slide. The cartridge is loaded against the cartridge drive roller which exerts a net radial dynamic force of 18 to 26 ounces. The motor is a brushless DC drive motor with integral capstan which is designed to provide maximum reliability.

The motor operates from the 12V nominal supply and moves the tape at speeds from 35 to 100 inches per second (IPS).

Chassis

The drive mechanism is mounted in a molded frame that provides the mounting holes for the industry standard 3.5-inch by one inch form factor. A 5.25-inch mounting kit is an available option. The bezel is a simple snap-on design that is available in several standard and custom colors. The front-panel LED is amber and indicates tape activity.

Control circuits

The control logic module shown in Figure 7-1 includes a buffer manager to handle data movement between the controller, the buffer, and the tape formatter. This module also includes logic to perform ECC and CRC generation and testing, WRITE/READ data formatting, head stepper control, and drive motor control.

The microprocessor directs all functions performed by the control logic. The instructions are read from a flash EEPROM, which can be updated with new firmware through a specially written tape cartridge.

The 512-Kbyte DRAM data buffer allows the drive to maintain streaming when the host cannot provide data continuously at the tape streaming rate.

The write driver receives data from the write formatter and generates write current, causing data to be written on tape by the tape head.

The read channel amplifies and conditions the signal from the tape head and passes it back to the read formatter.

The head stepper and drive motor both receive current from the control logic to control the stepping of the head from track to track and to move the tape forward and back across the tape head.

Head design

The recording/playback head is a state-of-the art, thin-film design—a thin-film inductive write head paired with an advanced magneto-resistive read head. This head design provides the drive with exceptional performance and reliability. The material composition of the head also results in exceptional wear characteristics, resulting in stable performance throughout the life of the drive.

Flash EEPROM

Because the drive uses flash EEPROM (electronically erasable, programmable read-only memory), the drive firmware can be easily upgraded when new revisions of the firmware are released. The circuitry includes 128 Kbyte of flash EEPROM.

You can load new firmware by using a specially encoded firmware upgrade cartridge. Refer to chapter 4 for information about loading new firmware using a Seagate firmware upgrade cartridge.

Sensors and switches

A number of mechanical and optical sensors and switches are integrated in the drive design. The Cartridge In switch detects when a cartridge is fully loaded and positioned against the A-plane datum of the cartridge. The Unsafe switch senses the position of the SAFE indicator on the cartridge and disables writing of write-protected (SAFE) cartridges.

The Head-Position Sensor is an electro-optical assembly (LED and photo-transistor) to determine the approximate head position.

The drive has an electro-optical sensor assembly comprised of a solid-state light source (LED) and a photo-sensor (photo-transistor) that sense the beginning-of-tape (BOT), end-of-tape (EOT), load point, and early warning holes of the cartridge.

Drive media (Travan minicartridges)

The drive is designed to use Travan TR-5 cartridges. These small (approximately 2 inches by 3 inches by 0.4 inch) cartridges house 1650-Oersted Gamma Ferric Oxide magnetic tape. Figure 7-2 shows a Travan minicartridge.

Figure 7-2
Travan minicartridge

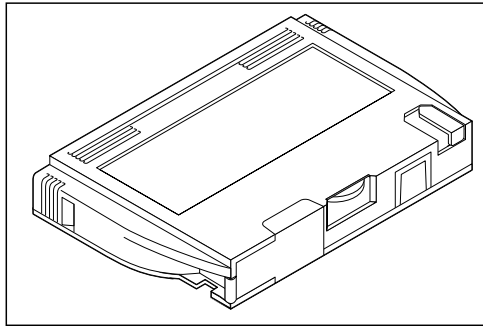

The cartridge also provides for write protection so that existing data on the cartridge is not overwritten. A write-protected cartridge allows the existing data to be read but does not allow new data to be written to the tape. The position of the sliding write-protect tab on the cartridge determines whether or not data can be written to the tape. See chapter 4 for illustrations of the write-protect position.

Glossary

A

ATA Packet Interface—The interface providing for communications between the host computer and the drive (standard QIC-157).

Azimuth—The angular deviation, in minutes of arc, of the mean flux transition line from the line normal to the tape reference edge.

Backup—Copy of a file or collection of files on fixed disk, diskette, or tape. Ensures against data loss.

Beginning of Media (BOM)—Equal to the physical beginning of the tape.

Beginning of Tape (BOT)—Equal to the logical beginning of the tape.

Bezel—Front panel of a drive.

Bit—A single digit in the binary numbering system.

Bit Error Rate—The number of errors divided by the total number of bits written or read.

Block—A group of 512 consecutive data bytes plus additional control bytes recorded as a unit.

BOP—Beginning of Partition. The position at the beginning of the permissible recording region of a partition.

BOT marker—The beginning of tape (BOT) marker is a set of two holes punched side by side in the tape.

Byte—A group of 8 binary bits operated on as a unit.

Cancelmark—A "negative" Filemark or Setmark. When a Cancelmark follows as the first block in the next frame after a Filemark or Setmark, the drive when reading the tape will logically ignore the Cancelmark and the Filemark or Setmark it cancels.

Cartridge—An enclosure containing magnetic tape wound on two coplanar hubs.

Control field—A group of 8 bytes recorded before the data area in each block, containing information about clock address, track address, and block type.

Cyclic Redundancy Check (CRC)—A group of 2 bytes recorded at the end of each block of data for the purpose of error detection.

Data block—A block containing user valid data in its data field

Data Compression—The process of removing redundant data from a data stream before recording the data to tape. Compressed data requires less storage space than uncompressed data.

Data Density—The number of single-byte characters stored per unit length of track. Usually expressed as bits-per-inch (bpi).

Decompression—The process of restoring compressed data to its original state.

Dew—Collection of moisture in a tape drive.

Directory track—The track at the centerline of the tape, identified as track 254 by its Track ID frame.

Disc Drive—A peripheral storage device that rotates the disk, writes data onto it, and reads data from it as instructed by a program.

ECC—(Error Correction Code) Special drive generated information that can be used to correct bad blocks.

ECC block—A block containing drive-generated ECC data in its data field and part of control field.

Encoding—A method whereby a group of data bits is translated into a group of recording bits.

End-of-Data (EOD)—Indicates the point where the host stopped writing data to the tape.

End-of-Media (EOM)—Equal to the physical end of tape.

End-of-Partition (EOP)—The position at the end of the permissible recording area of a partition.

End of Tape (EOT)—Equal to the logical end of the tape.

Error Correction Codes (ECC)- Information written on tape during the recording operation that can later be used to reconstruct errors during the data reading operation.

Early Warning (EW)—The early warning marker is a single hole punched in the tape to indicate the approaching end of the usable recording area in the forward direction.

File—A logical unit of information.

Filler block—A block containing no valid information in its data field.

Fixed Disk—A non-removable hard disk. All data must be transferred to and from the disk via the computer.

Frame—A group of 128 blocks forming a complete logical group.

Full-high (or full-height)—Usually refers to a tape drive fitting in a vertical space of 3-1/2 inches.

Half-high (or half-height)—Refers to the size of tape drive occupying a vertical space of about 1-1/2 inches.

Head Clog—Particles from the tape or from outside the drive adhere to the head gap on a read or write head and obstruct the reading or writing of data.

Interleaving—The process of shuffling the order of data blocks before writing them to tape so the consecutive bytes are not recorded physically adjacent.

Magnetic Tape—A tape that accepts and retains magnetic signals intended for input, output, and storage of data for information processing.

Media Header block—A unique block identifying the type of format being recorded.

Noise—A disturbance of the signal caused by the read channel, write channel, head/tape interaction, or conducted or radiated sources.

Randomizing—A re-coding of data symbols before they are written to tape in order to provide a consistently uniform RF envelope level.

RLL (Run Length Limited)—A data encoding method where data bits are encoded so that certain constraints are met with regard to the maximum and minimum distances between flux transitions.

Serpentine—A recording method in which tracks are laid down sequentially, and the tape is not rewound at the end of a track. This recording method exploits the bi-directional capabilities of the cartridge.

Streaming—A method of recording on magnetic tape that maintains continuous tape motion without the requirement to start and stop within an inter-block gap.

Tape Drive—A peripheral storage device that records data onto removable tape cartridges. Used to back up a disk drive. (See also Disk Drive.)

Track—A longitudinal area on the tape along which magnetic signals can be serially recorded.

Track ID block—A block recorded in the Load Point and Early Warning regions to designate the track number.

Uncorrected Bit Error Rate—The probability of a bit being in error, without using any error correction techniques.

Underrun—A condition developed when the host transmits or receives data at a rate less than required by the device for streaming operation.

Acronyms and measurements

B

Acronyms and abbreviations

Acronym	Meaning
ANSI	American National Standards Institute
BIOS	Basic Input Output System
BOM	Beginning of Media
BOT	Beginning Of Tape
BPI	Bits Per Inch
CD	Compact Disc
CMOS	Complementary Metal-Oxide Semiconductor
CSA	Canadian Standard Association
DMA	Direct Memory Access
ECC	Error Correction Code
ECMA	European Computer Manufacturers Association
EEPROM	Electrically Erasable, Programmable Read-Only Memory
EOD	End of Data
EOM	End of Media
EOT	End Of Tape
FCC	Federal Communications Commission
FTPI	Flux Transitions Per Inch
IEC	International Electrotechnical Commission
IPS	Inches Per Second
LED	Light Emitting Diode
LSI	Large Scale Integration

Acronym	Meaning
MTBF	Mean Times Between Failures
MTRR	Mean Time To Repair
OEM	Original Equipment Manufacturer
PCB	Printed Circuit Board
QIC	Quarter Inch Cartridge Drive Standards, Incorporated
RAM	Random Access Memory
RLL	Run Length Limited
SCSI	Small Computer System Interface
UL	Underwriters' Laboratories, Inc.
VDC	Volts Direct Current
VDE	Verband Deutscher Electrotechniker

Units of measurement

Measure	Meaning
A	Amp
C	Celsius or Centigrade
cm	centimeter
dBa	decibels, A-weighted sound power reference one picowatt
F	Fahrenheit
ft	foot or feet
g	acceleration of a free-falling body; equal to 32.17 feet per second ²
Gbyte	gigabyte
Hz	Hertz
in.	inch
k	kilo
Kbyte	kilobyte
kg	kilogram
KHz	kilohertz
lb(s)	pound(s)
m	meter
M	mega
Mbits	megabits
Mbyte	megabyte
MHz	megaHertz
min	minute
mm	millimeter
ms	millisecond
RPM	revolutions per minute
V	Volt
W	Watt